

# GEOExPro

GEOSCIENCE & TECHNOLOGY EXPLAINED

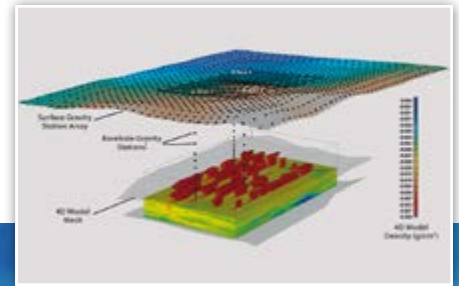

geoexpro.com

INDUSTRY ISSUES

TECHNOLOGY EXPLAINED:  
Borehole Gravity for  
Reservoir Monitoring

# Gas-to-Liquids: A Pipe Dream?

EXPLORATION

Paraguay: Heart of  
South America

HISTORY OF OIL

A Brief History of  
Booms and Busts

GEOPHYSICS

Ocean Bottom  
Seismic Makes  
Advances

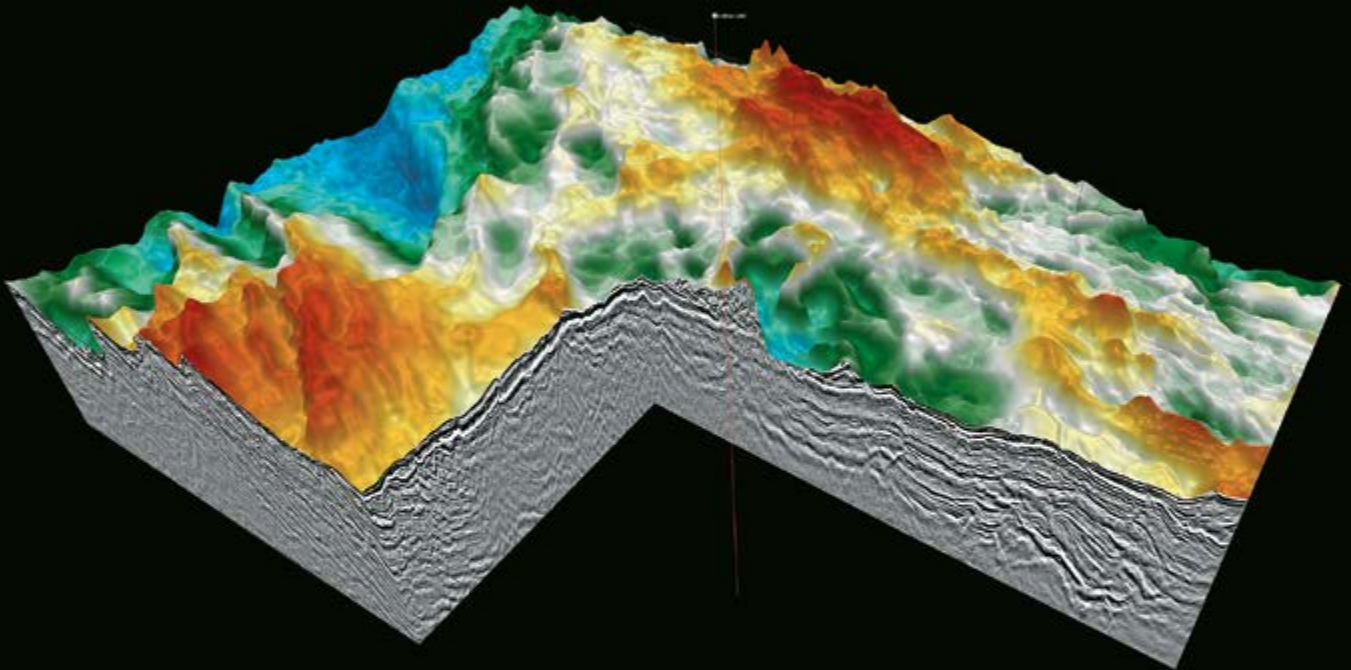

## Santos Vision

Discover the new Santos reprocessing with the latest technology available for Brazil Pre-salt Round evaluation

To learn more about PGS' leading seismic interpretation of our GeoStreamer MultiClient 3D-surveys, that can help de-risk opportunities in Brazil, please contact:

[brazilinfo@pgs.com](mailto:brazilinfo@pgs.com).



# GEOExPro

GEOSCIENCE & TECHNOLOGY EXPLAINED

20

Paraguay is surrounded by hydrocarbon-producing countries yet at the moment entirely dependent on imported oil and gas.

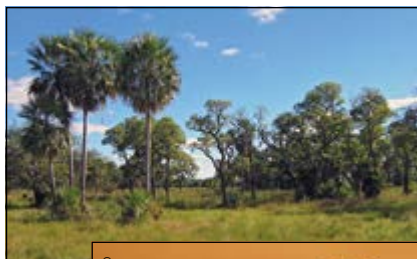

24

Dr. Ibrahima Diaby, CEO of PETROCI, hopes that hydrocarbon exploration will help Côte d'Ivoire to grow and develop.



46

Low energy prices provide a challenging environment for new liquefied natural gas projects.



52

In this two-part article we review the history of price fluctuations and oil shocks and the consequent booms and busts in the modern oil industry.



58

One of the many wonders of the Great Sand Dunes in Colorado is the rare phenomenon of surge flow, when a stream flows as rhythmic waves on sand.



## Contents

Vol. 14 No. 4

This edition of *GEO ExPro* magazine focuses on The Americas; Non-Seismic Geophysics; Natural Gas.

- 5 Editorial
- 6 Regional Update
- 8 Licensing Update
- 10 A Minute to Read
- 14 Cover Story: Industry Issues: GTL – More Than Just a Pipe Dream?
- 18 GEO Physics: Why Leopards *Can* Change Their Software Spots
- 20 Country Profile: Paraguay – Oil in the Heart of South America
- 24 GEO Profile: Ibrahima Diaby – Building the Future
- 28 Technology Explained: Modeling Exploration Strategies with CSEM
- 32 Recent Advances in Technology: Time Lapse Refraction Seismic II: Field Examples
- 36 [Seismic Foldout: Regional Play Types in the Mexican Offshore](#)
- 42 GEO Physics: The Future is at the Bottom of the Ocean
- 46 Technology Explained: A New Era for LNG
- 50 Exploration: Deep Offshore Exploration in Greece
- 52 History of Oil: A Brief History of Booms and Busts I
- 58 GEO Tourism: Unlocking the Mysteries of the Great Sand Dunes
- 62 GEO Physics: The Golden Snitch? Borehole Gravity for Reservoir Monitoring
- 66 GEO Media: Hubbert – The Oracle of Oil
- 68 Exploration Update
- 70 Q&A: US Tight Oil: Remaining Competitive?
- 72 Global Resource Management



# Unlock the power of the new DAKS™ IQ

The newest DAKS IQ is now available and ready to unlock your reservoir knowledge needs.

DAKS IQ is an analogs-based knowledge, reporting, and benchmarking platform that provides best practices and lessons learned from more than 1,500 of the world's most important fields and reservoirs. Covering over 400 geological and engineering parameters, DAKS IQ unlocks the insights of what has and has not worked, where and why.

With DAKS IQ you can quickly and easily discover ways to optimize recovery, support your decision-making process, and improve your overall financial performance across the entire E&P life cycle. Working in DAKS IQ means insights at your fingertips.

To learn more about DAKS IQ, visit us online at [ccreservoirs.com](http://ccreservoirs.com).

D · A · (·) · K · S™ · I · Q



## Gas is on the Rise

Humans have harnessed naturally occurring gas for over 2,500 years, since the Chinese made crude pipelines from bamboo shoots to transport seeping gas to the coast so they could boil sea water and make it drinkable. By the end of the 19th century natural gas was being piped short distances for street lights – but without quality metal pipes and a pipeline infrastructure, it was difficult to transport it very far.

Demand for gas as the greenest fossil fuel is on the rise; according to the *BP Energy Outlook 2017*, gas is the fastest growing fuel in the energy mix. It emits half the CO<sub>2</sub> of coal and a third less than oil when burned, as well as fewer pollutants. But the transportation of natural gas has remained a major hindrance to the efficient exploitation of reserves worldwide. Large gas discoveries like those off Senegal and Mauritania are heralded, but often with an aside about potential difficulties in monetizing the assets. Unnecessary volumes of associated gas are still being flared because of the problems of efficiently transporting the gas to market. Pipelines crossing hundreds of kilometers and several countries are difficult to plan, expensive to construct and potentially insecure.

Converting gas to a liquid form for ease of transport is the obvious answer. Various technologies to do this have been used for many years, but the expense of building onshore conversion plants or floating vessels, amplified by the common commercial model used for selling liquefied natural gas (LNG), with suppliers locked into long-term contracts, has limited the business.

This situation is changing. The International Gas Union reported that global trade in LNG reached a record 258 million tons in 2016 as new markets appeared worldwide. Technology is and will continue to prove key to this expansion, with new and more efficient methods of converting gas into liquids being developed, as we discuss in this edition. The global LNG market is expected to double by 2030. Flexibility in LNG contracts is increasing and deals are shorter, with natural gas becoming a global trading commodity like oil.

It's a new era for gas. ■



**Jane Whaley**  
Editor in Chief

### GAS TO LIQUIDS

Gas-to-Liquids, commonly known as GTL, involves the transformation of natural gas into synthetic oil. New techniques promise to reduce the complexity, and thus the cost, of the process. A feasibility study is underway for a GTL plant in northern Russia to produce winter diesel fuel from the natural gas of the Vasylovskoye gas condensate field, significantly reducing the cost of transporting fuel to this remote region.

Inset: Measuring borehole gravity can provide information critical to the successful characterization and monitoring of reservoirs.



© 2017 GeoPublishing Limited.

Copyright or similar rights in all material in this publication, including graphics and other media, is owned by GeoPublishing Limited, unless otherwise stated. You are allowed to print extracts for your personal use only. No part of this publication may be reproduced, stored in a retrieval system, or transmitted in any form or by any means electronic, mechanical, photographic, recorded or otherwise without the prior written permission of GeoPublishing Limited. Requests to republish material from this publication for distribution should be sent to the Editor in Chief. GeoPublishing Limited does not guarantee the accuracy of the information contained in this publication nor does it accept responsibility for errors or omissions or their consequences. Opinions expressed by contributors to this publication are not necessarily those of GeoPublishing Limited.

www.geoexpro.com

**GeoPublishing Ltd**  
15 Palace Place Mansion  
Kensington Court  
London W8 5BB, UK  
+44 20 7937 2224

**Managing Director**  
Tore Karlsson

**Editor in Chief**  
Jane Whaley  
jane.whaley@geoexpro.com

**Editorial enquiries**  
GeoPublishing  
Jane Whaley  
+44 7812 137161  
jane.whaley@geoexpro.com  
www.geoexpro.com

**Marketing Director**  
Kirsti Karlsson  
+44 79 0991 5513  
kirsti.karlsson@geoexpro.com

**Subscription**  
GeoPublishing Ltd  
+44 20 7937 2224  
15 Palace Place Mansion  
Kensington Court  
London W8 5BB, UK  
kirsti.karlsson@geoexpro.com

GEO EXPRO is published bimonthly for a base subscription rate of GBP 60 a year (6 issues). We encourage readers to alert us to news for possible publication and to submit articles for publication.

**Cover Photograph:**  
Main: INFRA Technology  
Inset: Micro-g LaCoste

**Layout:** Winslade Graphics  
**Print:** Stephens & George, UK

issn 1744-8743



# Mexico Revival

The revival of successful exploration is a much-needed breather for the Mexican oil industry.

Production has been decreasing in Mexico since 2007, in recent years by almost 9% annually, primarily due to the decline of mature fields and lack of new startups to compensate. The biggest discoveries in Mexico were made in 2008, the most successful year in the last decade, but that was followed by a sharp drop. Since 2012, when Pemex discovered the deepwater Trion field, an average of 400 MMboe resources have been discovered per year. Shallow water discoveries in the mature areas have taken an average of six to nine years to start up and recent finds are not substantial enough to reverse this declining trend. To counter this, Mexico introduced new reforms, opening conventional and unconventional exploration opportunities to international companies, which has successfully generated a lot of interest in the country.

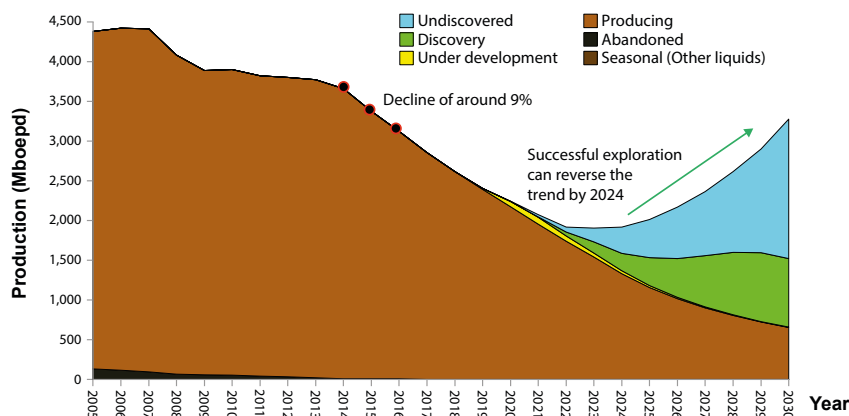

Total Mexico production split by lifecycle.

The first successful impact of this reform was the recent Zama discovery by Talos Energy (see page 69). In-place volumes are ~1.4 Bbo, and Rystad Energy estimates that the recoverable reserves are 511 MMboe. This discovery has highlighted the still sizeable unexplored possibilities in the Sureste Basin, which has been Mexico’s main producing area. In the recent License Round 2.1, 10 out of the 15 blocks awarded are in this basin.

Sureste consists of three main sub-basins: Villahermosa Uplift, Saline-Comalcalco, and Macuspana. Rystad’s creaming curves highlight that Villahermosa has had the most exploration activity, dating back to 1949, with more than 350 wells. The largest oil discovery in the basin, Cantarell, was made in 1976, followed by other major discoveries, including Ku (1979) and Maloob (1985). This Mesozoic sub-basin is light-oil-bearing to the south and has heavy oil towards the north-east. The Macuspana Sub-basin, in the south-western tip of the Sureste Basin, produces non-associated shallow gas and the offshore region is underexplored. Saline-Comalcalco has had little exploration since major discoveries such as onshore Cinco-Presidentes (1958) and the offshore Yakaan field (1984). The Zama discovery in this sub-basin has caused the creaming curve to spike again, with a new Miocene play that Pemex previously missed.

Until recently, most of the discoveries in Mexico were onshore and in shallow waters, and deepwater, despite some discoveries, is still considered frontier. In Licensing Round 2.4 the government has announced 30 mostly deepwater blocks. According to Rystad Energy estimates, Mexico offshore still has around 36 Bboe of undiscovered resources, with around 24 Bboe in Campeche and Perdido belts, and 5 Bboe in the Saline Sub-basin. There is also potential for about 1.5 Bboe in the Tampico Misantla Basin. Further successful exploration in these regions has potential to upturn production by 2024.

**Aatisha Mahajan, Exploration Analyst, Rystad Energy**

## ABBREVIATIONS

### Numbers (US and scientific community)

M: thousand	= 1 x 10 <sup>3</sup>
MM: million	= 1 x 10 <sup>6</sup>
B: billion	= 1 x 10 <sup>9</sup>
T: trillion	= 1 x 10 <sup>12</sup>

### Liquids

barrel	= bbl = 159 litre
boe:	barrels of oil equivalent
bopd:	barrels (bbls) of oil per day
bcpd:	bbls of condensate per day
bwpd:	bbls of water per day

### Gas

MMscfg:	million ft <sup>3</sup> gas
MMscmg:	million m <sup>3</sup> gas
Tcfg:	trillion cubic feet of gas

Ma: Million years ago

### LNG

Liquified Natural Gas (LNG) is natural gas (primarily methane) cooled to a temperature of approximately -260 °C.

### NGL

Natural gas liquids (NGL) include propane, butane, pentane, hexane and heptane, but not methane and ethane.

### Reserves and resources

**P1 reserves:**  
Quantity of hydrocarbons believed recoverable with a 90% probability

**P2 reserves:**  
Quantity of hydrocarbons believed recoverable with a 50% probability

**P3 reserves:**  
Quantity of hydrocarbons believed recoverable with a 10% probability

### Oilfield glossary:

[www.glossary.oilfield.slb.com](http://www.glossary.oilfield.slb.com)



# **BGP** – *Your reliable partner*

BGP is a leading geophysical contractor, providing geophysical services to our clients worldwide. BGP currently has 53 branches and offices, 65 seismic crews, 6 vessels and 14 data processing and interpretation centers overseas. The key business activities of BGP include:

- \* Onshore, offshore, TZ seismic data acquisition;
- \* Seismic data processing and interpretation;
- \* Reservoir geophysics;
- \* Borehole seismic surveys and micro-seismic;
- \* Geophysical research and software development;
- \* GME and geo-chemical surveys;
- \* Geophysical equipment manufacturing;
- \* Multi-client services.



**BGP Inc.**

Tel: 86-10-81201850 / 81201469  
E-mail: [marketing@bgp.com.cn](mailto:marketing@bgp.com.cn)

Fax: 86-10-81201392  
<http://www.bgp.com.cn>

# North Atlantic Acreage Available

## Canada

The Canada-Nova Scotia Offshore Petroleum Board has issued a call for bids on three large shallow water areas east of Cape Breton Island in the Carboniferous Sydney Basin. The area is virtually unexplored with no well penetrating to the most prospective horizons in the Lower Carboniferous, but the region is considered to have potential for both oil and gas, as active oil seeps from equivalent formations are present onshore Cape Breton. Bids must be received by December 14, 2017 before 4:00 p.m. Atlantic Time. Any successful bidder(s) will be awarded exploration licenses subject to federal and provincial ministerial approval. ■

## Norway

The 24th Norwegian Continental Shelf (NCS) round, announced in June this year, includes a total of 102 blocks, nine of which are in the Norwegian Sea and 93 in the Barents Sea. The application deadline is 12:00 on November 30, 2017 and new production licenses are expected to be announced in the first half of 2018. The Norwegian Ministry of Petroleum and Energy invited companies to nominate blocks for this round in August 2016 and as a result the blocks offered include ones close to existing production acreage and discoveries as well as new exploration acreage. Five of the Norwegian Sea blocks are in water depths of about 1,000m. The majority of the blocks, however, are in the Barents Sea, north of the Arctic Circle, which the Norwegian Petroleum Directorate's analyses suggest hold the best undiscovered resource potential on the Norwegian Sea. This area is expected to generate considerable interest. ■

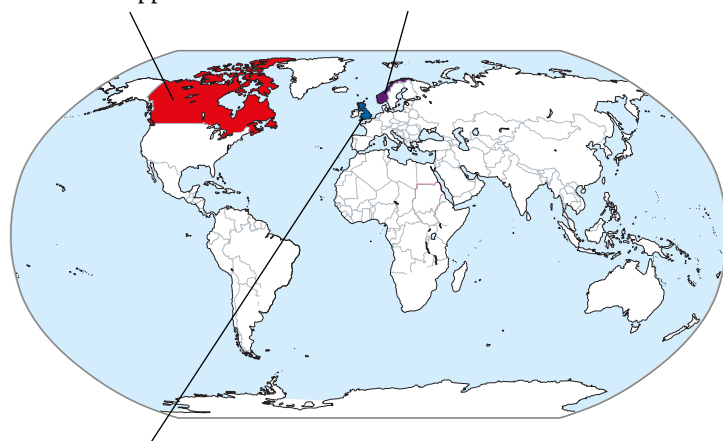

## United Kingdom

A total of 813 blocks or part blocks, covering 114,426 km<sup>2</sup>, have been made available in the UK 30th Offshore Licensing Round, which concentrates on mature areas of the UKCS. These cover the Southern, Central and Northern North Sea, the West of Shetland area and the East Irish Sea and include many undeveloped discoveries. The UK Oil and Gas Authority recently released around 140 datapacks detailing some of the discoveries that are included in the round to support companies in their technical assessments. Some of this acreage has not been made available since the early days of North Sea exploration in 1965. The round will make use of the new Innovate License, which has been developed in collaboration with industry to create flexible, variable licenses. The 30th Round is open until November 21, 2017 and decisions are expected to be made in Q2 2018. ■

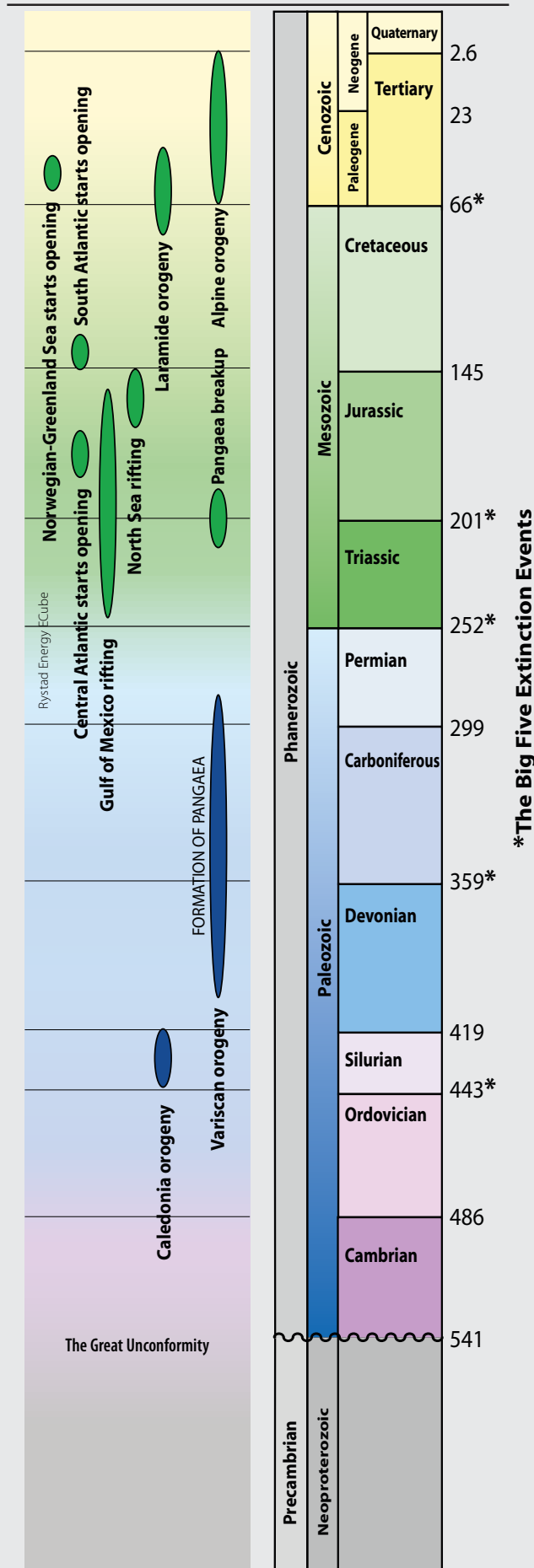



# Setting the Pace



*Data courtesy of Maersk Oil\**

\*Results from Dan Field Ocean Bottom Node (OBN) Survey – A Shallow Water Case Study. Zasko *et al.*, EAGE Conference (2014)

## Industry Leading Performance

Seabed Geosolutions continues our proven track record of operational excellence, QHSSE achievement and global expertise. Racing ahead of the pack with our innovative deployment and optimal source methods, Seabed Geosolutions remains the front-runner with the most comprehensive OBS solutions and efficiency enhancing node technologies available in the market today.

Seabed Geosolutions provides the fast track solutions to meet your exploration, appraisal and development goals.

To learn more, visit us at **SEG Houston booth 1525**.



[seabed-geo.com/Performance](http://seabed-geo.com/Performance)



## Collaborative Solutions – Sharing Success

Hosted by Malaysia's national oil company, **PETRONAS**, the **Asia Petroleum Geoscience Conference and Exhibition (APGCE) 2017** is Asia's premier geoscience event, where new plays and prospects will be presented by a gathering of technical gurus, industry experts and business leaders. APGCE 2017, which takes place November 20–21, 2017 at the **Kuala Lumpur Convention Center**, will welcome more than 2,000 international and local conference delegates, exhibitors and visitors. Carrying the theme '*Collaborative Solutions. Sharing Success*', the exclusive content will explore lessons learnt and value creation as well as solutions to overcome significant challenges in unlocking the exciting potential of Asian basins. It offers exciting opportunities for participants to build ties and strengthen existing business relationships.

Revolving around South East Asia acreages, the event aims to emphasize geoscience issues and challenges through informative platforms including technical oral and poster sessions. The carefully designed program has been tailored to meet the geoscience fraternity's current priorities, with presentations by government officials and business captains, as well as the mentoring of young and future geoscience enthusiasts through the EAGE Student Program.

Reflecting its reputation as Asia's premier geoscience event, many prominent geoscience speakers have already confirmed their participation, including Professors Paul Tapponnier, Robert Hall and Richard Swarbrick. Presentations from PETRONAS' geoscientists will cover the entire spectrum of geoscience subjects, including advances in formation evaluation, reservoir characterization, pore pressure predictions, source rock geochemistry and petroleum system modeling, as well as non-seismic methods and advances. Another returning highlight is the highly anticipated core display, featuring a variety of hydrocarbon-based samples from Malaysian basins.



The Kuala Lumpur Convention Center.

APGCE 2017 offers field trips to Sabah and the Pekan Delta in Pahang. The objectives of these are to gain better understanding of the tectono-sedimentary history and stratigraphic evolution, basic depositional processes, facies development, controls on sedimentation patterns and depositional environment, reservoir geometry and architecture and structural changes. There are also exclusive short courses conducted by technical experts, to be held from November 22–23 – and not forgetting the APGCE 2017 golf competition, which allows for further networking opportunities.

With the participation of a '*Who's Who*' of the industry's top management executives, geoscientists, geologists, geophysicists, technologists, engineers, analysts, stratigraphers, industry experts and managers, Asia's premier geoscience event is definitely one you cannot afford to miss! ■

## Why Dinosaurs – and Outreach – Matter

"Which of these is a dinosaur?" asks **Professor Ken Lacovara**, showing his audience pictures of a pterodactyl and a fluffy penguin chick (answer: the penguin, to the distress of the little girl in the front row). "Why is the word dinosaur a

The talk included photos of large-scale dinosaur excavations.



synonym for failure?" he challenges, comparing how long dinosaurs lasted with the time hominids have been around. His audience, a mixture of Petroleum Society of Great Britain (**PESGB**) members, their families and the public, are spellbound, as he ranges from humans descending from the fish family to the Chicxulub meteorite impact.

The talk, called 'Why Dinosaurs Matter', was part of the PESGB's **GEOLiteracy Tour**, a major outreach event aimed at raising the profile of geology and earth sciences in the public consciousness. Prof. Lacovara, an excellent public speaker who has unearthed some of the largest dinosaurs ever found, was giving the annual Stoneley lecture, which has been incorporated into this week-long event. The GEOLiteracy Tour travelled the UK, allowing a range of people to hear Prof. Lacovara, and included a field trip in the home of paleontology, Lyme Regis, as well as fun family activities.

The PESGB is a charity, and outreach and education of the general public is part of its remit. This excellent initiative is to be applauded. ■



# GEO 2018: Shaping the Energy Landscape

The **Bahrain International Exhibition and Convention Center** will play host to a critical exchange of oil and gas insights during the **13th Middle East Geosciences Conference and Exhibition (GEO 2018)** on **March 5–8, 2018**.

Held under the patronage of the Prime Minister of Bahrain, HRH Prince Khalifa bin Salman Al Khalifa, over 3,500 geoscientists and petroleum industry professionals from more than 50 countries will gather to debate and shape the future of the industry, build skills, network with peers and purchase products and services that will take their E&P programs to the next level.

The biannual event, established 24 years ago, incorporates a 4-day high-level conference under the theme 'Pushing the Technical Limits: Shaping the Energy Landscape', organized by the world's three largest professional geoscience associations (**AAPG, EAGE and SEG**) and a parallel 3-day exhibition organized by **UBM**. GEO 2018 is supported by an organizing committee of **NOCs, IOCs** and major service providers.

As Ahmad Al Eidan, GEO 2018 General

Chair and Deputy CEO, Drilling & Technology Directorate, Kuwait Oil Company, says: "GEO 2018 will be an extraordinary platform which will provide all participants with unlimited benefits and will open new frontiers for the current oil industry challenges." ■

*The busy Aramco stand at GEO 2016.*



## Venator, a total rethink in the design, cost, operational efficiency and safety within seabed acquisition.

- More than 10.000 nodes from one vessel
- Totally hands free back deck operations
- Fully automated Data and Battery Management
- Same system for all applications and water depths
- Scalable Containerized solutions available

**Up to 20 km<sup>2</sup> full azimuth acquisition per day**

Please visit us at SEG Houston, Booth 2001

**[www.inapril.com](http://www.inapril.com)**

**inApril**





## Introducing enhanced FTG

A recent significant advance in technology means that the existing generation of gravity gradiometers has now been surpassed by Lockheed Martin's next generation instrument, called the **enhanced Full Tensor Gravity Gradiometer (eFTG)**. This is the world's most advanced moving-base gravity gradiometer, possessing a noise floor approximately three times lower than the FTG and providing data with higher bandwidth.

The eFTG system combines the best design elements of preceding gravity gradiometers (partial tensor Falcon and full tensor systems) essentially comprising three digital Falcon discs



*The eFTG, designed and built by Lockheed Martin Corporation*

mounted in an FTG configuration. With its increased capability and performance, the benefits of the eFTG apply throughout the entire geological section, helping to deliver a more accurate Earth model.

**AustinBridgeport** are excited to offer the eFTG to the exploration industry on an exclusive basis. The system is survey-ready and can be deployed in airborne or on shipborne platforms. The eFTG will allow geoscientists to image subsurface structure and complexity in unprecedented detail, facilitating cost-effective exploration even in a 'lower for longer' oil price environment. ■

## Positive Change at Petrosys

**Petrosys**, a leading mapping, surface modeling and data management company providing software solutions for the E&P industry, recently announced that it had been acquired by the **Vela Corporation**, which manages and builds vertical market software businesses located throughout the world. This is expected to open up a new phase of growth for Petrosys, allowing stronger penetration of new markets, faster software development and more innovative R&D. It also provides access to a broad pool of management expertise

and software skills. As part of these developments **Scott Tidemann**, who has been with Petrosys for over 15 years in a range of roles, including senior management, software development and sales and marketing, has been promoted to Chief Executive Officer.

The Petrosys® software suite produces high quality maps and surface models. It manages seismic, well, geoscience and other specialized data used in the search for oil and gas at over 300 sites around the world. ■

## 3D Imaging Offshore Brazil



New discoveries continue to draw operators to the world-class petroleum systems of the **Santos** and **Campos Basins**, offshore **Brazil**. With this in mind, **ION Geophysical** recently announced a new 3D multi-client broadband reimaging program of this area, which will provide a regionally calibrated and consistently imaged **3D dataset** to give fresh insights into these basins ahead of upcoming license rounds. The program, which is known as **Picana**, involves the reprocessing and depth imaging of over 50 interconnecting public-domain 3D surveys, which together cover an area of more than 100,000 km<sup>2</sup>.

Picana aims to more clearly image the salt overlying thick crust and deep fault-bounded seaward dipping reflector complexes and, through mapping the petroleum systems, to develop new play ideas and identify prospects ahead of future Brazilian license rounds. The reprocessing will help to develop a consistent regional depth framework and comprehensive interpretation to better understand the region's tectonic architecture.

This large program, which is supported by industry funding, will be delivered in phases to provide relevant bid round knowledge as quickly as possible. The first 12,500 km<sup>2</sup> over Round 14 have been delivered to clients and the next 25,000 km<sup>2</sup> are in progress for December delivery. ■



# people powered

أرامكو السعودية  
saudi aramco



The power of our resources means nothing without the energy of our people. Their focus and expertise make our energy more dependable, more sustainable, and more useful.

We are looking for experienced geoscience professionals to join our team.

Apply now.

[www.aramco.jobs/geoexpro](http://www.aramco.jobs/geoexpro)



where energy is opportunity



# GTL More Than Just a Pipe Dream?

We have been converting natural gas into a liquid state for a long time, but the issue has always been making it cost effective. This environmentally-friendly technique is finally becoming more economically viable at both large and small scale.

**NIKKI RICCI,**  
INFRA Technology  
and **JANE WHALEY**

Gas-to-Liquids, commonly known as GTL, involves the transformation of natural gas into synthetic oil, which is easily conveyed by tanker or pipeline and can be used instead of conventional oil both in the petrochemical industry and in transportation infrastructure. GTL products are colorless and odorless, and contain almost none of the impurities like sulfur, aromatics and nitrogen that are typically found in mineral crude oil. Since natural gas burns much more cleanly than oil and is also more abundant, developing this technology would appear to offer

an important step in the future of energy supply and towards a cleaner environment. But, at least until recently, the main barrier to the mainstream use of GTL has been the complexity of the process – and therefore the cost.

### 100-Year-Old Technology

Changing natural gas into a liquid is not a new idea; in fact, synthetic fuel production technology was invented in the 1920s, when the most common technique, the Fischer-Tropsch (F-T) synthesis, was first developed. This was used in Germany in the 1930s and

particularly during WWII, when the country was finding it difficult to source conventional oil and refined product supplies. By 1944, Germany was using F-T technology at an industrial scale, with nine plants producing about 14,000 bpd.

South Africa was next to work on GTL technology, when anti-apartheid sanctions prevented the country from importing oil. Using coal as the feedstock, by the 1950s South Africa was producing several thousand barrels of synthetic oil a day, developing a number of plants over subsequent years; this is referred to as 2nd generation GTL technology.

*Pearl GTL is the world's largest plant turning natural gas into cleaner-burning fuels and lubricants.*





The technology continued to evolve, with gas becoming the preferred source. A number of major companies were at the forefront of this 3rd generation GTL development, including Shell, which built the Bintulu GTL plant in Malaysia in the 1990s. The company now operates the world's largest GTL plant, Pearl, which is capable of producing 140,000 barrels of GTL products each day, as well as 120,000 bpd of natural gas liquids and ethane.

The commercialization of this technology is still evolving, and there are only a handful of large, fully commercialized plants in the world, all complex and expensive to build and run. The main barriers to efficiency appear to be the low productivity of the Fischer-Tropsch reactors, short catalyst lifetime, by-products such as organic acids and heavy alcohols which have to be dealt with and, most importantly, the need to build petrochemical plants to turn hard waxes produced by the standard F-T method into marketable products.

Methods of producing liquids from gas outside the F-T process, without the use of catalysts, have also been developed, in which air or oxygen is burned together with natural gas at high temperatures and pressure to cause particle oxidation, but these have yet to be proved commercial.

Therefore, although the F-T process is now nearly 100 years old, the cost of GTL, in small-scale operations at least, remains very expensive.

### Breakthrough to 4th Generation

An innovative Houston-based company believes it has found a solution to unlock the economic efficiency of the GTL business. INFRA Technology has developed new catalysts which allow synthetic fuels to be produced with no by-products, directly from the Fischer-Tropsch reactor without the wax stage, leading to significant cost savings – potentially up to 50% of the CAPEX of conventional GTL technologies. The process is uniquely optimized for the production of clean hydrocarbons without oxygenates, thus

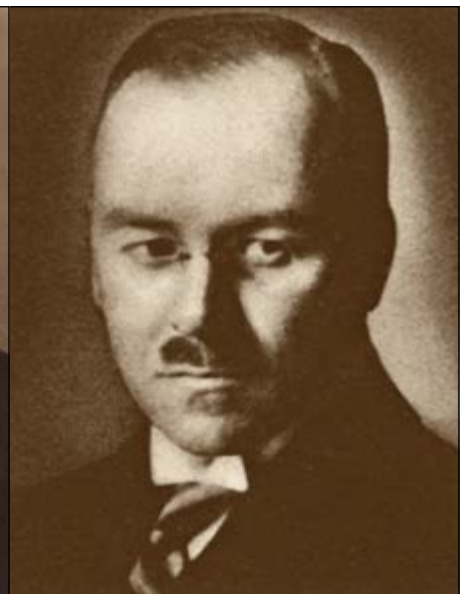

*Franz Fischer and Hans Tropsch invented the technique named after them which converts gas or coal into synthetic liquid fuel.*

reducing further waste management issues. We are now looking at the 4th generation of GTL technology – and a major step forward towards commercialization of this process at all scales.

INFRA's technology is differentiated by the use of a unique proprietary pelletized cobalt-based catalyst in the F-T stage of the process, using a modularized tubular fixed-bed reactor, with the catalyst packed inside the tubes. The F-T reaction is carried out at constant temperature as cooling water is circulated on the shell side to maintain the reaction at isothermal conditions. The produced water is collected and reused for the auxiliary and steam system. The waste heat generated from the F-T block by the reactions and the energy absorbed by the F-T cooling water cycle at high temperature and pressure is industrialized, generating enough power to supply the motor-driven

equipment. This has all led to a dramatic improvement in efficiency.

The clear synthetic crude produced mixes well with mineral crude for a number of uses, and by offering slightly different catalysts to suit the preferred liquid product composition, the INFRA F-T process can directly deliver distillates like naphtha, diesel and jet fuel which do not contain impurities such as sulfur, nitrogen, tar or carcinogenic aromatic hydrocarbons.

Another advantage of the technology is a reduction in the size of the reactor, making modular and scalable plant design economically viable. From its small

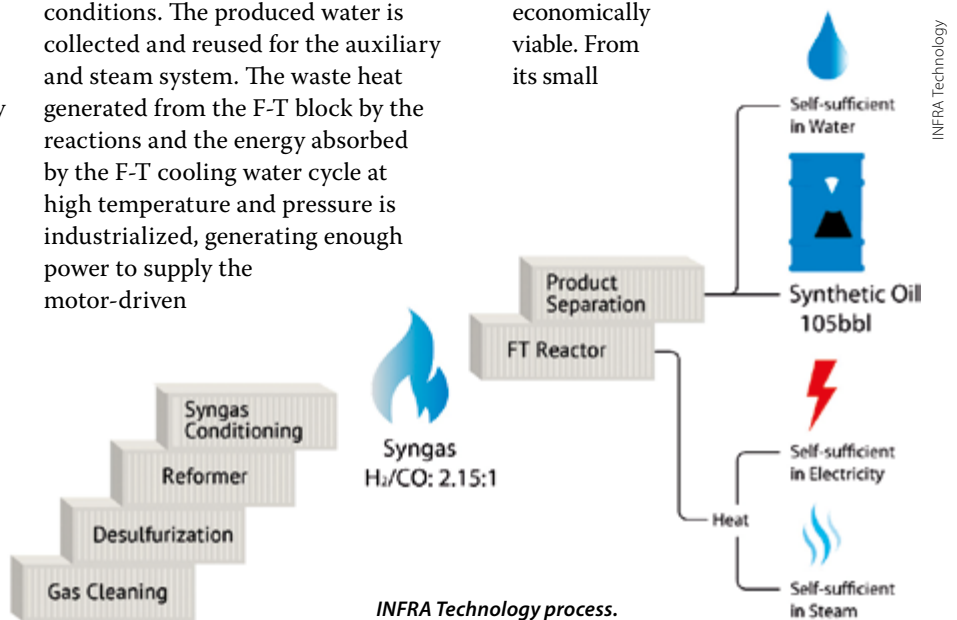

INFRA Technology

## How Does GTL Work?

Gas-to-liquids is the process of converting gaseous hydrocarbons into longer-chain hydrocarbons, such as gasoline or diesel fuel.

Traditionally, converting gas to liquids using the F-T method consists of three stages. First, natural gas is broken down through high temperatures to create synthetic gas or 'syngas', primarily hydrogen and carbon monoxide. Impurities are removed before a second stage converts the syngas, using high pressure and temperature and a catalyst, into liquid hydrocarbon, which looks and feels like wax at room temperature. Efficient removal of heat is a basic need of F-T reactors since these reactions

are characterized by the release of large quantities of heat. Building a plant which can withstand these volumes and pressures as well as the heat is highly expensive.

The final stage is cracking and isomerization, which rearranges the molecule chains into high quality liquid products such as diesel, kerosene and lubricant oil. Large quantities of water are produced as a by-product, which must be treated before disposal or reuse, and a lot of heat is generated in the process which must also be dealt with.

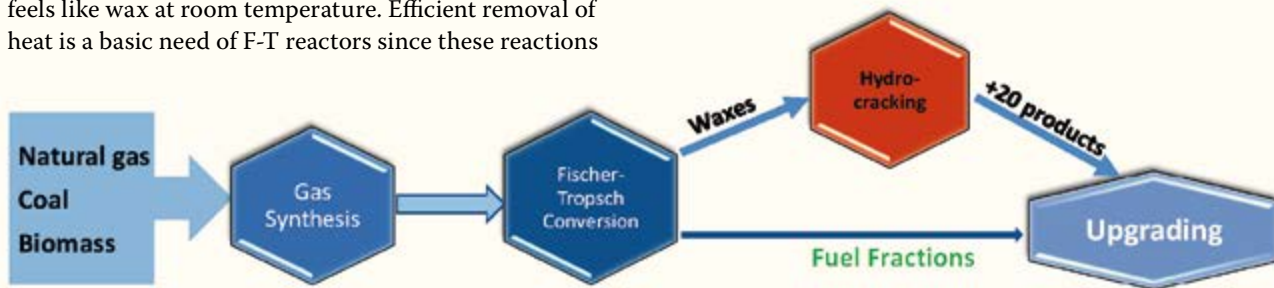

demonstration pilot plant in Texas INBRA Technology can produce more than 100 barrels of synthetic oil (60/40 mixture of gasoline and diesel fractions with a high share of jet fuel) from 1 MMcf of gas per day, which it believes can ensure a positive NPV for GTL plants on a standalone basis even for small-scale facilities. INBRA has designed a modular transportable gas-to-liquids unit which has a footprint of only 400 m<sup>2</sup>, which can be placed on an onshore drillsite or offshore platform to convert flared associated gas into liquids and can also be easily relocated to another site.

networks instead of flaring could be an important and economically viable route to tackling these emissions. As an added bonus, GTL technology can cope with CO<sub>2</sub>-rich gas, the presence of which can make a field unviable; in fact, up to 25% CO<sub>2</sub> in the feed actually increases productivity.

Stranded gas – discoveries remote from any market or in other ways economically unviable – represent almost a third of the world's proven gas reserves. At the moment either

gas pipelines or LNG terminals and tankers are the most feasible options, but both are expensive and complex in construction, operation and maintenance for all but the largest resource deposits. Immense pipelines, transmissions stations, gas liquefaction terminals and liquefied gas tankers together result in an extremely expensive infrastructure, meaning that for many projects, the transportation of the product itself can make the entire field development project unprofitable.

*GTL technology can be used in conjunction with bio-gasification technology to economically provide a new source of clean and renewable energy.*

### Advantages of Low Cost GTL

Right now, more than 16,000 gas flares are burning associated gas at oil production sites worldwide, causing about 350 MMt of CO<sub>2</sub> and other pollutants to be emitted into the atmosphere every year. As well as being bad for the environment, this wastes resources which could be used. In 2015 alone over 5 Tcfg was burnt through flares at production sites – enough to supply the entire continent of Africa with electricity for a year, according to the World Bank. The installation of small, low cost GTL units at wells or clusters of wells which use the gas to directly produce synthetic oil that can be transported and sold using existing

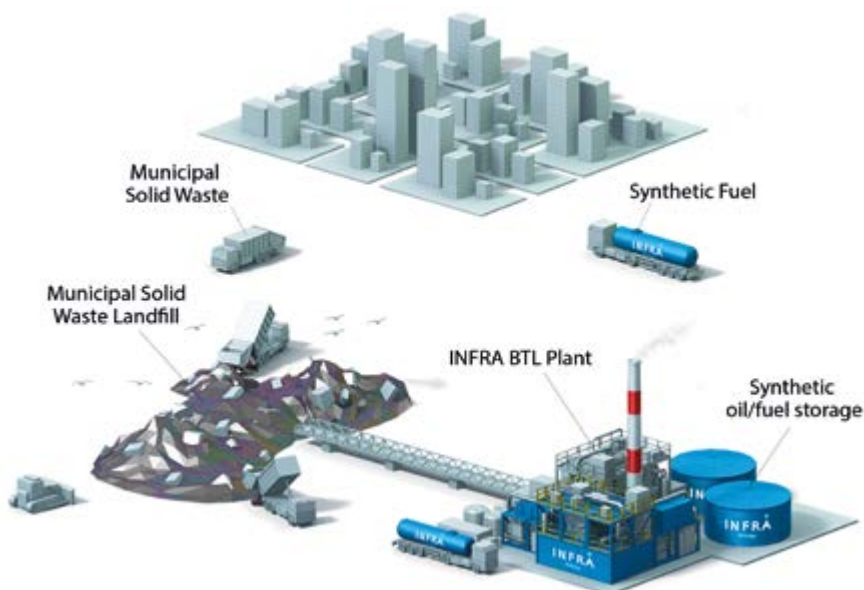

INBRA Technology



The ability to install a compact, cost-efficient GTL system which does not require additional energy input or produce polluting by-products is a way to unlock and monetize such stranded gas resources. This is particularly relevant for developing countries without established infrastructure systems. The economic efficiency of INFRA's GTL production in remote areas is demonstrated by its use in Russia, where the most effective projects, which have a financial internal rate of return of 16.5–25%, are in inaccessible areas like Sakhalin, Novy Urengoi, and Surgut.

Similarly, the burgeoning shale gas industry can benefit from small-scale GTL technology by converting gas into synthetic crude at the source, offsetting high production costs with a good value-added product and eliminating the need for gas transportation infrastructure, thus adding to the potential for these resources.

Moving away from hydrocarbons, small-scale GTL technology has tremendous potential in the bio-resources field, as existing technologies do not allow for the production of transportation fuels from these sources. If bio-gas is being produced, either from agricultural and

forestry products or biologically derived waste, such technology can help make it more economically viable while also providing a new source of clean and renewable energy.

Synthetic fuels have been shown to have a number of benefits, including lower emissions and enhancements in engine performance, a very important factor when considering the level of air pollution in many cities. This fuel is completely free from the toxic impurities produced when cars burn mineral motor fuel, producing only steam and carbon dioxide, and is compatible with existing diesel and petrol engines, as well as transportation infrastructure and gas stations distribution systems.

There are many implications in the use of small-scale GTL technology for countries keen to strengthen their national energy independence through the diversification of energy sources, as well as offering more import and export options through a larger range of transport routes.

#### **Future Looks Promising**

By producing high quality synthetic oil that does not require hydrocracking or upgrading, through a very efficient

process, INFRA Technology believes that for the first time in history synthetic fuel production has become profitable. Having proved the technology by opening the first commercially feasible GTL plant in Texas, which demonstrates the modular, transportable GTL idea, the company is now looking to develop larger projects which, through economies of scale, will be not only economically viable, but cost-competitive with oil refining, thus bringing natural gas and bio-resources to the crude oil and transportation fuels markets. There are ongoing discussions with Petronas in Malaysia to develop a floating GTL plant, and a feasibility study is underway for a GTL plant in the Nenetsk region in northern Russia, which will produce winter diesel fuel and high-octane gasoline from the natural gas of the Vasytkovskoye gas condensate field. This will enable the region to become self-sufficient in diesel and gasoline, significantly reducing the current expensive cost of transporting fuel to this remote northern region.

It looks as though the efficient production of synthetic fuel is finally both feasible and profitable and is destined to become the rule rather than an exception. ■

*INFRA Technology opened its first commercially feasible GTL plant in Texas in December 2016.*



# Why Leopards Can Change Their Software Spots

The take-up of innovative software is often held back by the effort involved in a long learning process.

**ALEX STEDMAN, Shearwater GeoServices**

Turning seismic waves into images of the sub-surface has been around for about as long as the seismic waves themselves. First came the needle wobbling on a steady stream of paper and the geophysicist, armed with pens, attempting to pinpoint where the hydrocarbons had been lying dormant for millennia. The invention of the computer gave the western world a quantum leap in almost every part of working life, and allowed geophysicists to take digital signals and turn them into images of oil and gas reservoirs.

Although technology has improved, however, the principle has remained the same. And just how far has technology improved? Is the industry really utilizing the most recent advancements? Moore's law, the famous

observation made by Intel co-founder Gordon Moore in 1965, states that computing power doubles every year. With this in mind, is last year's technology this year's old news?

## The Trouble with Computers...

... is that we're only human. Humans are great at a lot of things. It only takes a cursory glance around to see all the innovations that have brought us to where we are today. We learn quickly (compared to our animal cousins), and can develop great skills through repetition. Tie this in with the well-known idea that "*the more difficult the task, the sweeter it is to succeed*", and we find that if we have a tricky skill

to develop then we feel pretty good about ourselves once we've mastered it. The trouble with that, of course, is that once we're invested in these skills it is difficult to break away from them.

At this point you may be asking what this has to do with modern technology. The answer is that the most modern technology could be put in front of us right now, but if the old technology has required us to invest a lot of time, effort and concentration, then many of us would be reticent to adopt new methods – even if it would benefit us to do so. We would feel like all our previous effort was wasted.

## Revealing Possibilities

When the first small processing algorithms started to make their way on to the geophysicists' computers, they required a lot of effort just to get running. It was common to use punch-cards to tell the computer what to do. Is it any wonder that there are still seismic software packages today that use electronic versions of punch-cards, with column widths of only a few characters?

Iterative developments, held back by a highly-skilled population invested in old technology, creates a niche for easy-to-use, easy-to-adopt, modern geophysical software. Over the last few years, we have started to see this type of software penetrate a market that has until now been dominated by a small number of legacy packages. Shearwater GeoService was launched last year as an acquisition, processing, multi-client and software company. Its latest software, Reveal, is a classic example of filling the demand for a modern, powerful and easy-to-use product. Algorithm development is no longer the sole

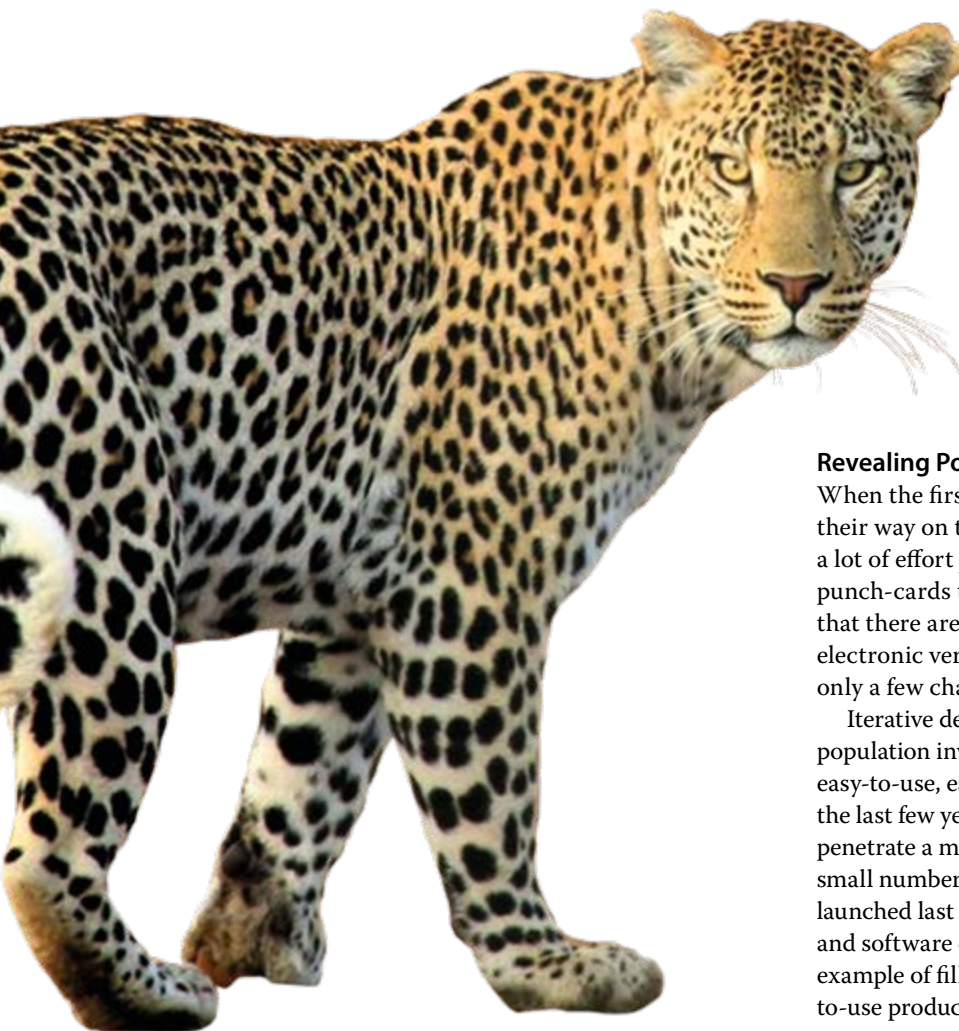



driver in geophysical software development; the user experience is taking joint-first place in the round-table discussions. Graphic designers are seen in the same meetings as software engineers, with a collaborative culture permeating the 21st-century outlook.

At the heart of this development is the user experience. The power is given back to the users in a simple and intuitive interface that allows them to build their own creative geophysical space. It is not just the usability of Reveal that is important to the developers at Shearwater, but also the users' transition from legacy to modern software. Like most other packages that have been built within the last few years, there has been just as much thought for the geophysicist behind the keyboard as there has been for the algorithms behind the processing. Similarly, it is important that migrating from the old packages to new ones like Reveal is easy and requires minimal training. It should be intuitive enough that new users feel comfortable with using this software within a few weeks.

#### Can a Leopard Change its Spots?

All this doesn't just apply to software, nor exclusively to the oil and gas exploration industry. Innovation is not held back by a lack of technology, nor by a lack of brilliant people coming up

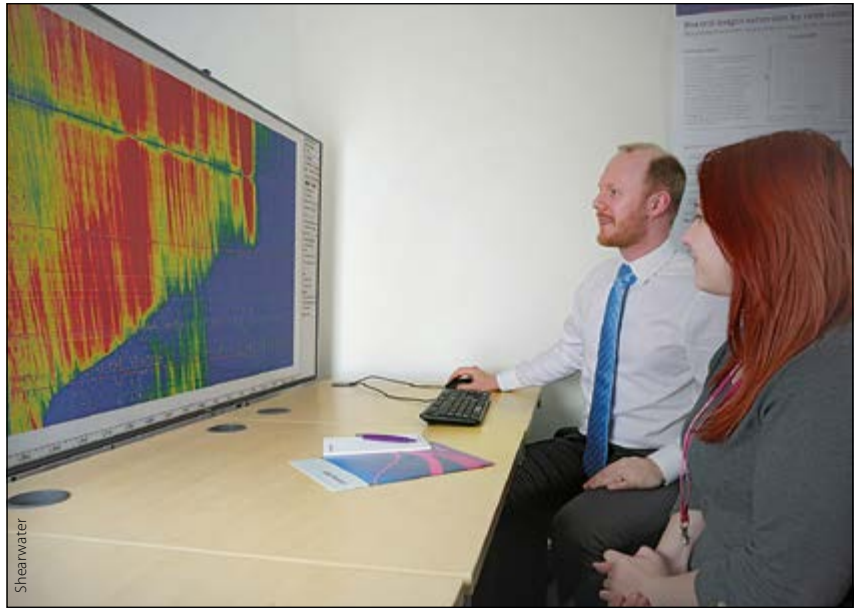

*Demonstrating the ease of the Shearwater software.*

with great ideas. It is held back by the rest of us who are proud of our skills and achievements in niche categories, and feel that to 'change our spots' would be too much effort. Let's put that to one side and start looking for the new and inventive solutions to the status quo. Let's look at the possibilities that we didn't know were there.

And once we start looking, let's never stop. ■



## The next generation Gravity Gradient System is worth its weight in gold

In collaboration with Lockheed-Martin we now exclusively operate the state-of-the-art **enhanced FTG** system

By combining the technological advantages of all previous gradiometer designs, the eFTG has:

- The highest available signal to noise ratio of any moving base gravity system
- Improved out-of-plane interpolation accuracy due to lower noise floor
- A dynamic 4D capability

These benefits allow cost effective planning of your seismic acquisition footprint.

To learn more about the eFTG and our other services please visit us at the **SEG International Exposition, Houston, booth 1821**, or online at [www.austinbridgeporth.com](http://www.austinbridgeporth.com) or contact us at [sales@austinbridgeporth.com](mailto:sales@austinbridgeporth.com)





# Oil in the Heart of South America

JANE WHALEY

**Landlocked Paraguay is surrounded by hydrocarbon-producing countries yet remains entirely dependent on imported oil and gas. With prospective resources estimated to be in the region of 4 Bbo in the Chaco Basin region alone, and more than 50% of the wells drilled showing evidence of hydrocarbons, could this be about to change?**

In the 1920s and '30s Paraguay fought a bloody seven-year war with Bolivia over the Chaco region, partly fueled by rumors of huge oil reserves lying beneath the area. Paraguay won the war and the extra territory – yet despite the drilling of more than 50 wells since then, the first potentially significant discovery of hydrocarbons in the country was not made until 2014. With hydrocarbon-producing regions in Brazil, Argentina and Bolivia to the east, south and north-west respectively, it is not surprising to learn that in 2011 the USGS estimated Paraguay's undiscovered hydrocarbon resource potential to be 27.95 Bboe, the majority in the Paleozoic. These estimates include unconventional resource potential; the US Energy Information Administration (EIA) in 2013 forecast unproven wet-shale gas technically recoverable resources for Paraguay to be 75 Tcf.

## **Long History, Little Success**

Exploration in the Bolivian Foothills section of the Chaco Basin has been ongoing since the 1900s and has resulted in the discovery of a number of large fields, but this has not been replicated over the border in Paraguay. It was not until the 1940s that the first seismic was acquired in the country, by Union Oil, who drilled five wells in the west between 1947 and 1949. Despite some indications of gas, there was then a ten-year drilling hiatus, and only seven further wells were drilled by 1967. Pennzoil entered the fray in 1971, looking at very shallow Devonian oil deposits, but none of the 16 wells they spudded in western Paraguay that year proved commercial.

A seismic study by Exxon in the Chaco region in the 1980s led them to pull out of the area after drilling a single well – but with the benefit of hindsight it appeared that explorers at

*Paraguay is dominated by grassy plains and wooded hills in the south-east and in the north-west by the marshy plains and low forest of the sparsely populated Gran Chaco seen here.*





the time were trying to replicate the discoveries over the border in Bolivia rather than look at correlations with Argentina. More than half of the 20 wells drilled between 1971 and 1997 actually found evidence of hydrocarbons, including the first few wells drilled in the eastern Paraná Basin, but dry hole analysis suggests that many were not valid structures and none proved the breakthrough needed. Exploration once again ground to a halt.

The end of the 35-year repressive dictatorship of Alfredo Stroessner in 1989 was the impetus for a 1995 change in the hydrocarbons law, making it more attractive for foreign investors. Shortly afterwards a Russian consortium acquired seismic and prepared prospectivity studies, which gave a positive interpretation. However, only one further well was drilled before 2012, when President Energy undertook an extensive seismic campaign, including the first ever 3D in the country, to evaluate the Chaco Basin potential and define high-graded drilling prospects. This was followed up by two wells in the basin in 2014, which proved an active petroleum system and found evidence of good oil- and gas-bearing Paleozoic sands. After a long time in the doldrums, maybe Paraguay's potential is finally be about to be revealed.

## Two Main Sedimentary Basins

Paraguay lies at the center of South America where several major cratons meet, bounded on the west by the Andes and on the north-east by the Brazilian shield. The main structural lineaments trend north-west and north-east, and periods of reactivation throughout the area's geological history have resulted in subsidence and the deposition of significant thicknesses of sediment.

The Paraguay River, which runs north-south through the middle of the country, roughly divides it geologically, with the western half dominated by thick Tertiary and Quaternary sediments. To the east of the river Mesozoic and Paleozoic sediments and Mesozoic volcanics overlie Precambrian and early Paleozoic crystalline basement, which outcrop as topographic highs. There are two main basins separated by the Asuncion anticline, which is roughly parallel to the Paraguay River.

The large Paraná Basin reaches from northern Argentina through Uruguay to central Brazil, and extends into south-west Paraguay, where it covers an area of 110,000 km<sup>2</sup>. It is dominated by Mesozoic sediments towards the east, with older Paleozoic material present towards the basin edges close to the Paraguay River, in places amassing over 5 km of sediment. The basin developed in north-east to south-west elongated depressions which follow the Precambrian substrate. The Paraná Basin has remained at moderate burial depth throughout its history and the bulk of thermal maturation probably took place during the late Jurassic to early Cretaceous igneous episode.

West of the Paraguay River is the Chaco Basin, a large intra-cratonic asymmetric foreland basin located



predominantly in north-western Paraguay and south-eastern Bolivia. It is structurally relatively simple, with scattered, mainly vertical, normal faults and none of the thrusting typical of Andean tectonics further to the west. It has a thick covering of Tertiary terrestrial sediments, predominantly fine sands and clays, underlain by older rocks. Over 2 Bcf/gpd and 50,000 bopd have been produced from this basin in Bolivia and Argentina, and estimates have suggested that the Paraguayan section could hold at least 4 Bbo.

## Promising Petroleum Systems

A Paleozoic petroleum system has been recognized in the Paraguayan Paraná Basin, analogous with fields like Barra Bonita across the border in Brazil, but only a handful of wells have been drilled to date. The most recent was Amerisur's Jaguareté-1 in 2016, which found indications of oil and gas in low porosity Devonian sandstones, possibly sourced from Devonian black shales.

The Paleozoic sequence in the Chaco Basin is dominated by shallow marine clastics and organic-rich deeper marine shales, with Silurian and Devonian shales providing the main source rock for the Paleozoic petroleum system, with interbedded sandstones as the primary reservoirs. By contrast, the Mesozoic rocks are predominantly continental, deposited during periods of intense rifting and magmatism associated with the opening of the South Atlantic. Potential reservoirs include volcanics, similar to those found over the border in Argentina's Palmar Largo field, and stacked fluvial and lacustrine sediments, together with eolian sands and shallow marine carbonates. Upper Cretaceous/Lower Paleocene carbonates and shales provide the main source rocks.

As the Andean mountain ranges developed to the west during the Cenozoic, they provided a new sediment source

## Country Profile

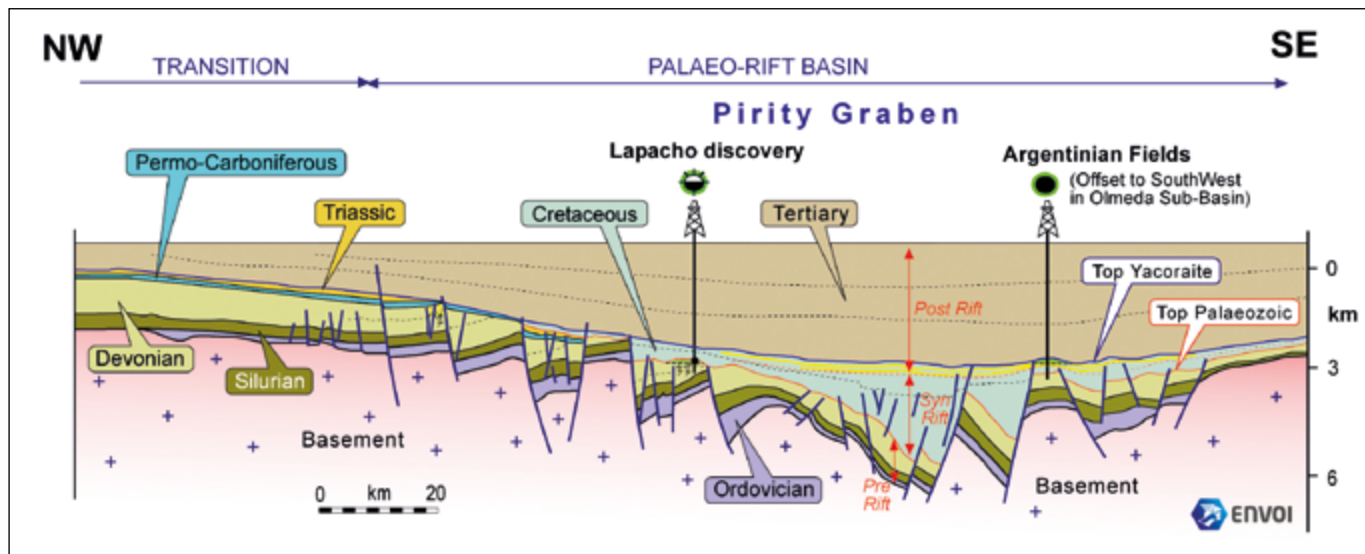

Cross-section through the Pirity Sub-basin (for line of section, see map on page 21).

to infill the Mesozoic sub-basins, depositing up to 3,000m of fine sands and clays. The faulting and uplift which resulted from this deformation created most of the structural features and resulting traps in the Chaco Basin, often reactivating Mesozoic rift-related structures.

At the deeper level the Paraguayan Chaco Basin is divided into four sub-basins: Pilar, Pirity, Carandaity and Curupaity. The last two were originally considered the most prospective, and almost half the wells drilled have been in Carandaity, most in the '70s, while the Curupaity has only four wells. The main geological targets in these two sub-basins are Carboniferous and Devonian, sourced by Devonian and Silurian shales, with the Mesozoic cover thinner and less prospective than further south. Carandaity is considered gas-prone, while a slightly lower source rock temperature means Curupaity is likely to contain oil.

South-east of Carandaity is the Pirity Sub-basin, which has been attracting interest in recent years because it extends south-westwards into Argentina, where 152 MMboe

have been produced from a number of fields in the same Cretaceous rift. These include Palmar Largo, lying just 20 km from the border, which has produced over 50 MMbo from Upper Cretaceous volcanic reservoirs, which are also present in the Paraguayan section. Similar structures can also be seen in Pirity, with tilted Paleozoic fault blocks being the main traps, charged from the down-dip central basin kitchens in the Cretaceous, and potential additional charge from Devonian and Silurian sources.

In 2014 President Energy drilled two wells targeting the Paleozoic gas play in the Pirity Sub-basin, proving for the first time that the prolific Devonian and Silurian petroleum systems of south-east Bolivia and north-west Argentina extend into Paraguay. The first, Jacaranda, found carboniferous reservoirs without topseal, plus 800m of Devonian source rock but only limited upper Devonian reservoir before the well was TD'd. Inadequate seal is an issue which has dogged a number of Paraguayan wells. The second well, Lapacho, found oil in the Lower Devonian and gas in deeper Silurian, although testing was terminated prematurely due to mechanical problems.

The Pilar Sub-basin is thought to be a pull-apart basin characterized by steep north-west to south-east basin bounding faults with intrusions related to early Andean orogeny. It is essentially unexplored, with a single dry well drilled back in 1949, and is thought to hold considerable thicknesses of potentially hydrocarbon-generating marine Devonian sediments.

### Unconventional Potential

In addition to conventional hydrocarbon resources, Paraguay is believed to have considerable unconventional potential. Risked technically recoverable shale gas and oil resources from the thick Devonian shales in the Paraguay portion of the Paraná Basin are estimated (EIA) to be in the region of 8 Tcf shale gas and 0.6 Bb shale oil and condensate, while rocks of the same age in the





Chaco Basin are thought to have 67 Tcf shale gas and 3.2 Bb shale oil and condensate. The gas window in this basin is reportedly at about 2 km depth and the structural setting is relatively simple.

In total, this suggests that Paraguay has the fifth largest resource base in Latin America. Although this has yet to be actively investigated, a number of companies with conventional licenses in the country are interested in following up this potential.

### Promising Future

Paraguay imports and consumes around 33,000 bpd of refined products, the majority from Argentina and the United States. Little is used for electricity, as hydropower from the massive Itaipú and Yacyretá dams on the Paraná River provides nearly 100% of Paraguay's electrical needs, with 90% of the electricity generated exported – a welcome source of income. The only refinery, built just outside the capital, Asunción, was mothballed in 2005 as it was more cost-effective to bring in refined oil, but it could be reopened if sufficient quantities of oil were discovered. There are also export options to Argentina.

The country has had a relatively turbulent political history since the overthrow of dictator Stroessner, including major political upheavals culminating in the assassination of a president in the late 1990s, the impeachment of another president in 2002, and the ousting of President Lugo in 2012. However, it does have fully democratic elections and since 2014 the economy has grown at a 4% average annual rate while other countries in the region have contracted. The government is keen to diversify economically and offers the oil and gas industry an attractive economic and fiscal regime, with a sliding scale royalty of 10–14% and a corporate tax rate of 10%. This means that even medium-sized fields could give good returns, especially in comparison to the more mature areas in neighboring countries. Permits are traditionally awarded for an initial one year, which can be converted to a concession with a four-year exploration period involving the drilling of one well. With a discovery, this progresses to a 20–30 year exploitation period.

*The Jesuit Missions of La Santísima Trinidad de Paraná were founded in 1609 and declared a UNESCO World Heritage Site in 1993.*

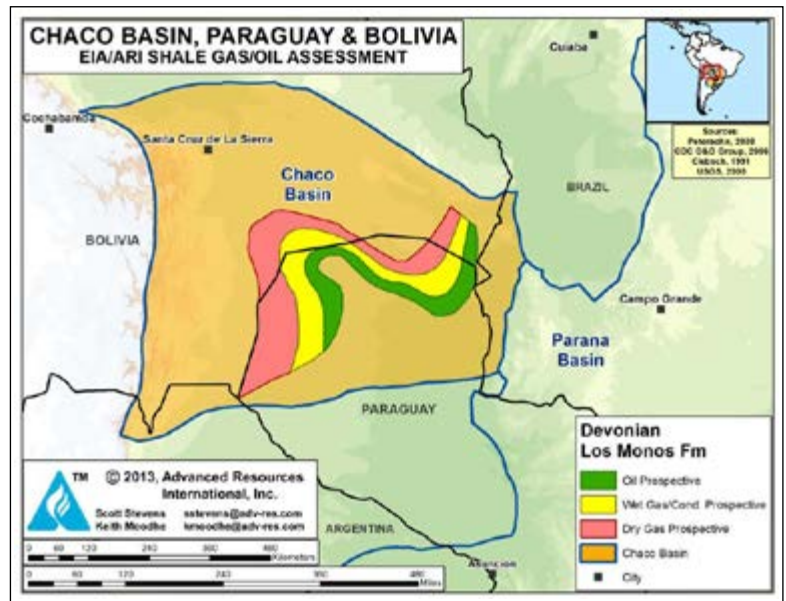

*The Chaco Basin is thought to have significant unconventional hydrocarbon potential.*

Given the similarity in geological settings between Paraguayan basins and neighboring hydrocarbon-producing regions, plus the fact that the whole country is underexplored, the potential for finding commercial hydrocarbons seems very promising. Most wells were drilled over 40 years ago, and many were shallow and drilled on little geophysical data. Exploration was piecemeal and sporadic, with no geochemical work and little attempt at regional analyses.

Reprocessed seismic data, recent concepts in seismic stratigraphy and the analysis and interpretation of multiple databases from several previous operators suggest that, despite the current lack of production and the slowdown in exploration due to lower commodity prices, there is every expectation that Paraguay will soon join the company of South American hydrocarbon-exporting nations.

*References available online.*

*Acknowledgement: Many thanks to Envoi Ltd and to President Energy for assistance with this article. ■*



# Building the Future

Having experienced some of the hell of civil war, Dr. Ibrahima Diaby, the CEO of Côte d'Ivoire's state oil company PETROCI, hopes that exploration for oil and gas will help his country to grow and develop.

JANE WHALEY

The West African country of Côte d'Ivoire is a modest hydrocarbon producer at the moment, but, as Dr. Ibrahima Diaby, CEO of PETROCI Holding, the country's national oil and gas company, says, there is plenty of potential for this to change, even in an era of \$50 oil. "We are the only country in West Africa where all the natural gas produced is used locally, providing 80% of our electricity supply – and we are pushing producers and explorers to find and deliver more natural gas to meet projected growth in electricity demand."

## Studying Abroad

Dr. Diaby was pondering what career to pursue when someone gave a talk about earth sciences in his last year at high school – and the decision was made. "I was good at science, math and physics but also liked being outdoors, and here was someone telling me about a job I could do with these skills, yet without being tied to a desk!" he explains. "I realized my country was in need of mining geologists and was lucky enough to get a scholarship to study in the US, so I headed there in 1974. It was a big culture shock; until then the furthest I had traveled was to two neighboring West African countries. And I arrived in winter – it was so cold! But I love meeting people and soon found friends. Although I had studied some English at school, my first languages are Dioula and French, so before I could begin the undergraduate course I had to spend several months improving my language skills. That was enjoyable, with a great group of international students, but

I was keen to get into the lecture room, so I was very happy when, after a few months, I was able to start my studies in geology at Oregon State University."

After getting his bachelor's degree, Ibrahima found himself at a cross roads and had to decide whether to follow a 'hard rock' career in mining, or move into the relatively new field, for Côte d'Ivoire at least, of petroleum geology. "When I started as an undergraduate the only hydrocarbon exploration in my country had been in colonial times. Little had been found, but the country had a very appealing iron ore mining potential thanks to the vast banded ironstones in the West African craton part of the country," he explains. "However, in 1974 we finally had a significant discovery – the offshore Belier field – which helped me decide on petroleum geology, so I went to the university of Illinois to take an MSc in sedimentary geology.

"I was very fortunate to have been awarded a scholarship, but this only took me to the Masters level, so then I had another decision to make – to continue my studies alone or return home. There was a position available to me with PETROCI,

but I was very keen to get a PhD if I could. At the time I was considering teaching at university level as an option at some stage in my career – something I'd still like to do – so I

*Dr. Diaby speaking at the International Tribunal for the Law of the Sea arbitration between Côte d'Ivoire and Ghana.*

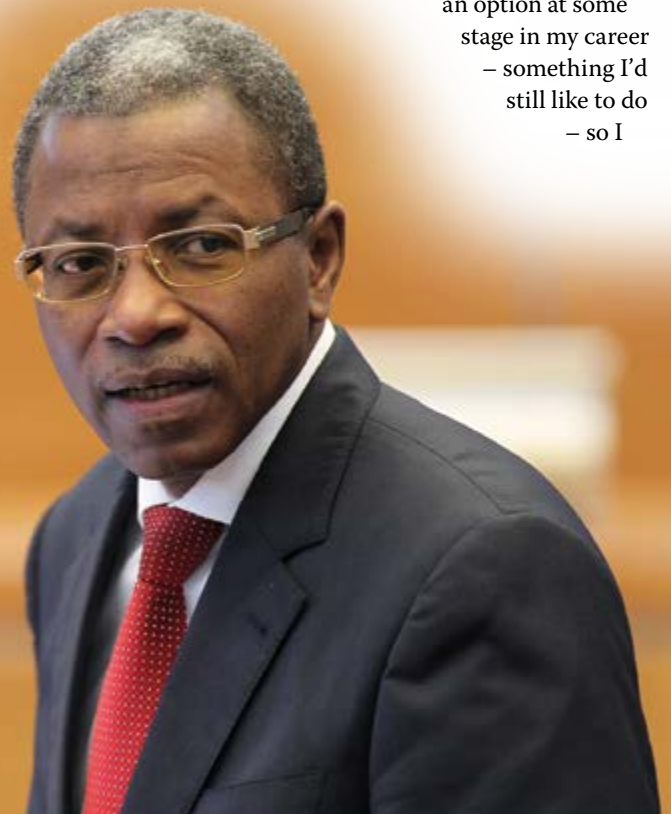



decided to continue with my studies. I had various part-time jobs and also worked as a research and teaching assistant to cover costs and get more experience while doing my PhD.

### Mapping Côte d'Ivoire

In 1984 Dr. Diaby returned to his home country and a job in PETROCI, where he was involved in managing the hard data stored there and in setting up the sedimentology laboratory and core library. "I spent some time going through boxes of cuttings and thin sections and organizing petrography and petrophysics, before we got a scanning microscope, which made the job much easier. PETROCI was much smaller then, only about 150 people – it's now about 470 people – and everyone knew everyone else.

"In 1987 the Minister of Mines asked me to head up the Geological Survey, who were just starting a new major mapping project, with the assistance of the French Geological Survey, as well as German and Canadian support," he continues. "Previously, Côte d'Ivoire had been mapped primarily at the 1/500,000 scale, but we managed to cover more than half of the country at the 1/200,000 scale. These programs also involved a geochemical strategic mapping project on various Precambrian greenstone belt areas. We had 10 mapping teams of young geologists who spent long periods in the field, and every month, except during the rainy season, I traveled all over the country visiting them. It was a very rewarding and enriching experience; many of the field geologists were locals with BSc degrees and this work helped them get advanced diplomas and degrees and move on to new jobs with mining companies, including SODEMI, the mining parastatal in the country.

As Director of the Mines and Geological Survey Dr. Diaby was also involved in the drafting of the 1995 mining code and its fiscal regime and actively participated in an international promotional drive for iron and gold mining investments in the country. With the hard rock nature of the geology in Côte d'Ivoire, this was quite a challenge for a sedimentologist – he had to dig out his undergraduate course notes to remind himself of what it was all about. From a marginal gold producer status in the 1990s (about 2 metric tons/year) Côte d'Ivoire now produces over 20 mt/y.

### Scholarships Important

In 1998 Dr. Diaby moved back to PETROCI, and from 2000 to 2003 was Director of Hydrocarbons and later Technical Advisor at the Ministry of Mines and Energy. Unfortunately, however, as the country spilled deeper into civil war, he had to leave the Ministry and work independently for a number of years.

"For a time I headed the local office of a consulting firm in Abidjan, before working alone as a consultant on various missions in West Africa, covering not just petroleum and mines, but also things like the management of fishing activities. Towards the end of the war, in 2010 and 2011, I traveled to Togo and Burkina Faso for work and had to remain there as it was too dangerous to return. It was a terrible time, and so stressful," he adds. "I had my phone with me all the time, just waiting for bad news. I lost relatives, as well as friends, and was fortunate to be out of the country myself as I may not have survived – but my wife and kids were still there, so it was very worrying. They finally got out

# WE HAVE BELOW SEISMIC TUNING IN THE PALM OF OUR HANDS



## APPLY MACHINE LEARNING TO MULTI-ATTRIBUTE ANALYSIS

Extract greater information and insights from seismic and well data than otherwise possible using traditional interpretation methods.

## VISUALIZE THIN BEDS WITH BELOW SEISMIC TUNING

Thin beds identified with this methodology enable more accurate mapping of facies below tuning and are not restricted by traditional frequency limitations.

## IDENTIFY DIRECT HYDROCARBON INDICATORS (DHIs)

Identify DHIs more efficiently and accurately, reducing risk in prospects and projects.



Geophysical Insights, "From Insight To Foresight", Paradise, and "Multi-Attribute Analysis lives here" are registered trademarks of Geophysical Research, LLC. All rights reserved. 2010-2017 inclusive.

of the war zone before the end of the war, thank God!"

In 2011 the UN and other international intervention helped end the war, the country became more peaceful, and Ibrahima was able to return home. "Abidjan was full of potholes, with grim marks like bullet holes on the walls," he remembers, "but it wasn't too badly destroyed, as it hadn't been bombed out, like some war zone cities seen in international news."

"On my return I was appointed as a Special Advisor to the Minister of Mines, Petroleum and Energy and in August 2011 became General Director for Hydrocarbons at the Ministry of Petroleum and Energy. In this post I led negotiations for 25 new Production Sharing Contracts (PSC), which were signed between December 2011 and April 2017.

"I also coordinated and implemented a scholarship program for undergraduate Ivorian students studying abroad, the previous one having terminated in about 1980. Being the beneficiary of such a scholarship myself, I know how important it is to ensure our young people are well trained, with some having experience abroad," he explains. "In the PSCs we obtained a budget for training in geosciences and energy so young Ivoirians could study in places like the US, UK, Canada and France as well as locally. Over 100 are studying abroad at the moment and there is also some short-term foreign vocational training. The first batch of students are due to graduate next June. Some will continue to Masters level, and others will find work back home with PETROCI. Hopefully some of our oil company partners will start development projects soon, allowing them to employ young Ivoirian geoscientists and engineers."

"We also have our own National University and the polytechnic college in Yamoussoukro, which both produce good graduates in geosciences and engineering. I think it is useful for companies like PETROCI to have both nationally and internationally trained graduates in order to get a broad range of ideas and points of views."

### Looking to the Future

Having kept at bay the Ebola epidemic which so decimated its neighbors, primarily through stringent sanitary methods and public hygiene, Côte d'Ivoire is looking forward to a brighter future, and Dr. Diaby believes that oil, and particularly natural gas, will prove an important part of that. Recently appointed to his role as CEO of PETROCI Holding, he believes that diversification will prove important for the future.

"We can't just sit around waiting for oil to return to the \$80 plus levels – we must survive with the current prices," he says. "With this in mind, PETROCI has set up a pipeline operation and is a partner in a new LNG company. We believe that the offshore basin is gas-prone, and gas is key to our plans. At the moment our fields provide 220 to 240 MMcfd, all of which is used by local independent power producers, and we would like to find enough gas to supply the 10% predicted annual growth in electricity demand. About 70% of the population has access to electrical power – more in the cities – and we are diversifying sources with solar and hydroelectricity as well as natural gas. Some companies are close to a final investment decision on new fields which we expect will be agreed soon, hopefully with a suitable and stable gas price for long term investment."

"We are a very modest oil producer at the moment – about 100,000 boepd," he continues, "but we would like to double that by 2020. At the moment we export the light crude (about 42,000 bopd) we produce and we import and refine heavy crude oil. I hope that oil and gas will be a key contributor in helping my country grow and develop," he adds.

For a number of years Côte d'Ivoire has been in discussions with Ghana over their respective maritime territorial limits, after the latter began to fast track developments in the border region, although no maritime territorial agreements have been signed between the two neighbors. Since November, 2011 Dr. Diaby has been involved in these discussions as a technical co-leader for the Côte d'Ivoire team. After the two countries failed to come to an agreement, in September 2014 the case passed to the International Tribunal for the Law of the Sea (ITLOS), a UN institution based in Germany. The final decision of the Special Chamber of ITLOS is expected to be delivered in September this year. The two countries have stressed, time and again, their good relations and readiness to cooperate in implementation of the ITLOS ruling.

### Advice for the Young

What advice would Dr. Ibrahima Diaby give to young African geoscientists considering a career in the oil and gas industry?

"Well, the world has changed a lot since I started, so the first thing I would say is, be sure that this is really what you want to do. Also, look at the environmental and societal aspects of everything you undertake and make sure your training includes an understanding of how your work affects your local environment, as well as the bigger picture; I think this is very important. Internationally, China is becoming an ever bigger player in oil and gas and in world trade, so keep that in mind. And don't forget that scientists can make a big difference and play an important role in so many areas of a nation's life."

"Most of all, I want our young people to realize how important peace is for the country, and for all her neighbors," he adds.

*"La paix n'a pas de prix! Peace is Priceless!"* ■

*Dr. Diaby (left) at a small marginal field PETROCI is involved in in southern Mississippi, USA.*







# Modeling Exploration Strategies

What is the value of systematic use of controlled source electromagnetic information in frontier exploration?

DANIEL BALTAR and NEVILLE BARKER, EMGS

The value of information (VOI) depends on the targeted decision, how the information is used to affect this decision, and, of course, the information itself. In 2011, at a time when most controlled source electromagnetic (CSEM) surveys were small, 2D and prospect-focused, Buland et al. calculated CSEM VOI for a drill-or-drop decision. In such a case, the maximum value the information can have is the well cost, as the best outcome from an information-value perspective is that the well is not drilled. Today, however, most proprietary and multiclient surveys are 3D, and cover larger areas. The quality of CSEM information has continued to improve, and interpretation workflows have been developed with which it is possible to impact predictions of risk and volume (Baltar and Barker, 2015), and flow capacity (Baltar and Barker, 2017). Here, we calculate a reasonable CSEM VOI for a full exploration project today, and consider the implications for exploration strategy.

## Modeling Frontier Exploration

In a frontier setting, information is particularly limited. Several large structures or stratigraphic features may be identified in seismic, but it is difficult to assess fill-potential, and volumes present, if filled. Prospects therefore typically have a low probability of success (PoS), with high P10 and low P90 volumes (large P10/P90 ratio). Let us consider such an acreage, comprising 20 prospects, where several wells are committed and the acreage will be relinquished if no economic discovery is made. The decision as to which prospects to drill can be made at no cost.

In our synthetic portfolio, each prospect has a PoS drawn from a uniform distribution of between 0.05 and 0.2, and a P10 recoverable volume, drawn from a loguniform distribution of between 300 and 2,500 MMboe (Figure 1a). A constant P10/P90 ratio of 40 is used to derive P90 recoverable volume, and volumes are lognormally distributed. For the

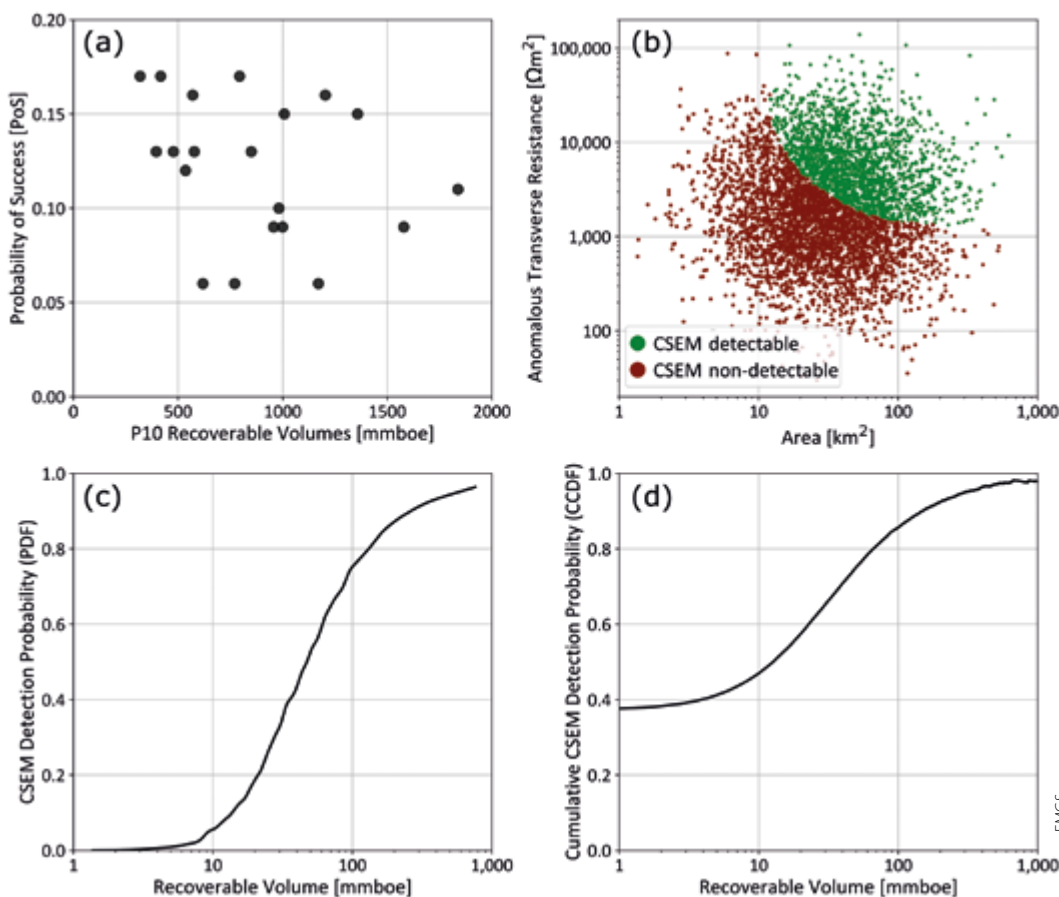

Figure 1: (a) our synthetic exploration portfolio; (b) a Monte Carlo simulation of one representative prospect in the portfolio, buried 3.5 km below mudline, and categorized into those scenarios detectable by a specific CSEM equipment-set, and those that are not; (c) and (d) probability of detection by CSEM for this portfolio as a function of recoverable volume (density and cumulative form respectively). The ability of CSEM to detect a hydrocarbon accumulation is strongly dependent on the filled-reservoir volume, and we can see this dependence for our portfolio in c and d.



sake of simplicity, all prospects are buried at the same depth, 3.5 km below mud line, with 2 km water; their chances of success are independent; and they do not overlap, so only one prospect can be drilled with one well.

Different strategies could be followed when drilling this portfolio, so we will model two alternative decision-makers. In Strategy 1 we will attempt to maximize the PoS and upside-potential by drilling in descending PoS x P10 order, while in Strategy 2, we will acquire CSEM over all the acreage and utilize the same priority list as in Strategy 1, but will postpone the drilling of those prospects where no associated CSEM anomaly has been identified. This is about the simplest reasonable decision-maker that can be conceived for CSEM at the portfolio scale.

We can now use Monte Carlo modeling with 500,000 iterations to simulate our two drilling strategies. Both strategies will use the same data, but in Strategy 2 the filled cases will then be assigned a probability of CSEM detection based on their volume (from Figure 1). To account for false-positive risk, 20% of the dry cases will also be considered CSEM positive, as used by Buland et al., 2011; from our first-hand experience with modern 3D surveys and interpretation workflows, this is very conservative. The final Strategy 2 drilling sequence will then be the Strategy 1 sequence of the EM-positives, followed by the Strategy 1 sequence of the EM-negatives.

Figure 2 shows the mean simulation outcome, where economic success is calculated with respect to a minimum

economic field size of 300 MMbo. With Strategy 1, in the absence of CSEM, the cumulative probability of economic success ( $Pe$ ) increases almost uniformly with the number of wells (Figure 2d). The introduction of CSEM leads to a more rapid increase in cumulative  $Pe$  for the first wells, with a reduction in the rate of increase after only a few wells. In other words, the acreage is being more efficiently created.

### Value of CSEM Information

The value of the CSEM information is the expected difference in the project's value with and without the CSEM. Project value can be calculated with the following formula:

$$V_{exp} = NPVe Pe - (1 - Pe) C_{exp}$$

where  $V_{exp}$  is the value of the exploration venture,  $NPVe$  is the average Net Present Value of an economic success, and  $C_{exp}$  is the cost of the exploration project. We weight the cost of exploration by  $1 - Pe$  because we consider this cost to be discounted from the  $NPVe$ .

The CSEM value stems from the increased chance of making an economic discovery in one of the committed wells. The increase in  $V_{exp}$  can be written as the difference between the expected value of each of the branches of the corresponding decision tree:

$$\Delta V_{exp} = \Delta [NPVe Pe] - \Delta [(1 - Pe) C_{exp}]$$

For a technology to be valuable,  $\Delta V_{exp}$  must be greater than zero, and hence  $\Delta [NPVe Pe]$  must be greater than  $\Delta [(1 - Pe) C_{exp}]$ .

Let's now take our exploration acreage and include a commitment to 3D seismic acquisition and the drilling of

FINDING  
Petroleum
EVENTS  
2017/18

<p><b>FINDING OIL AND GAS IN SUB SAHARAN AFRICA</b> <i>London, 19 Sep 2017</i></p>	<p><b>CARBON MANAGEMENT AND THE OIL AND GAS INDUSTRY</b> <i>London, 20 Nov 2017</i></p>
<p><b>CONNECTING SUBSURFACE DATA WITH E+P EXPERTISE</b> <i>Kuala Lumpur, 03 Oct 2017</i></p>	<p><b>TRANSFORMING OFFSHORE OPERATIONS WITH DIGITAL TECHNOLOGY</b> <i>Stavanger, 30 Nov 2017</i></p>
<p><b>TRANSFORMING OFFSHORE OPERATIONS WITH DIGITAL TECHNOLOGY</b> <i>Kuala Lumpur, 04 Oct 2017</i></p>	<p><b>NORTH AFRICA AND THE EASTERN MEDITERRANEAN</b> <i>London, Dec 13</i></p>
<p><b>GEOPHYSICAL TECHNOLOGIES OTHER THAN CONVENTIONAL SEISMIC</b> <i>London, 11 Oct 2017</i></p>	<p><b>FRACTURED RESERVOIRS AND OTHER ROCKS!</b> <i>London, 23 Jan 2018</i></p>
<p><b>FINDING OIL IN MEXICO AND THE CARIBBEAN</b> <i>London, 17 Oct 2017</i></p>	<p><b>FINDING EAST &amp; SOUTHERN AFRICAN OIL &amp; GAS</b> <i>London, 21 Feb 2018</i></p>
<p><b>SOLVING E&amp;P PROBLEMS WITH MACHINE LEARNING &amp; ANALYTICS</b> <i>London, 13 Nov 2017</i></p>	<p><b>FINDING &amp; EXPLOITING NEW PETROLEUM RESOURCES IN EUROPE</b> <i>London, 21 Mar 2018</i></p>

[www.findingpetroleum.com](http://www.findingpetroleum.com)

*To promote, for the public benefit, education in the scientific and technical aspects of petroleum exploration*



**Join the community**

Active/Associate Membership

From £5 a month

Student Membership

From £2.50 a month

Significantly discounted **member rates** to PETEX, PROSPEX, Africa Conference and various PESGB training courses - **you only need to attend ONE of these events to recover your membership fee!**

**FULL MEMBERSHIP**  
**Monthly Direct Debit**  
 £80 per annum (£5 per month)  
**Annual Direct Debit**  
 £55 per annum  
**Annual Payment**  
 £65 per annum

**STUDENT MEMBERSHIP**  
**Monthly Direct Debit**  
 £30 per annum (£2.50 per month)  
**Annual Direct Debit**  
 £25 per annum  
**Annual Payment**  
 £35 per annum

[pesgb.org.uk](http://pesgb.org.uk)

## Technology Explained

two exploratory wells at a total cost ( $C_{exp}$ ) of US\$500 million. This leads to a Strategy 1  $Pe$  in the range of 3 to 6%. In contrast, with the addition of CSEM, the Strategy 2  $Pe$  is 17% (Figure 2c). The cost of a CSEM survey depends on the water depth, area to be covered, and receiver spacing (which can be relatively sparse in a frontier setting). A reasonable upper limit for the type of project needed here would be US\$40 million. Using this budgetary figure we can now compare  $\Delta[NPV_e Pe]$  with the cost of CSEM (Figure 3a). For any reasonable project (with original  $V_{exp} > 0$ ), the  $\Delta[NPV_e Pe]$  significantly outweighs (by more than 20 times) the upper limit of the CSEM cost. This means that the value of a typical exploration venture can be greatly increased by systematic use of CSEM to improve the drilling sequence.

Interestingly, as well as improving the portfolio creaming, the addition of CSEM also leads to a change in the project's economic threshold: with the increase in  $Pe$ , there is a corresponding change in the position of the  $V_{exp} = 0$  line (Figure 3b), one of the potential exploration-venture threshold criteria. Therefore the additional value gained from CSEM is large enough that projects with significantly smaller  $NPV_e$  may now be considered.

The use of CSEM information for drilling sequence improvement, as detailed here, is a very simple application of

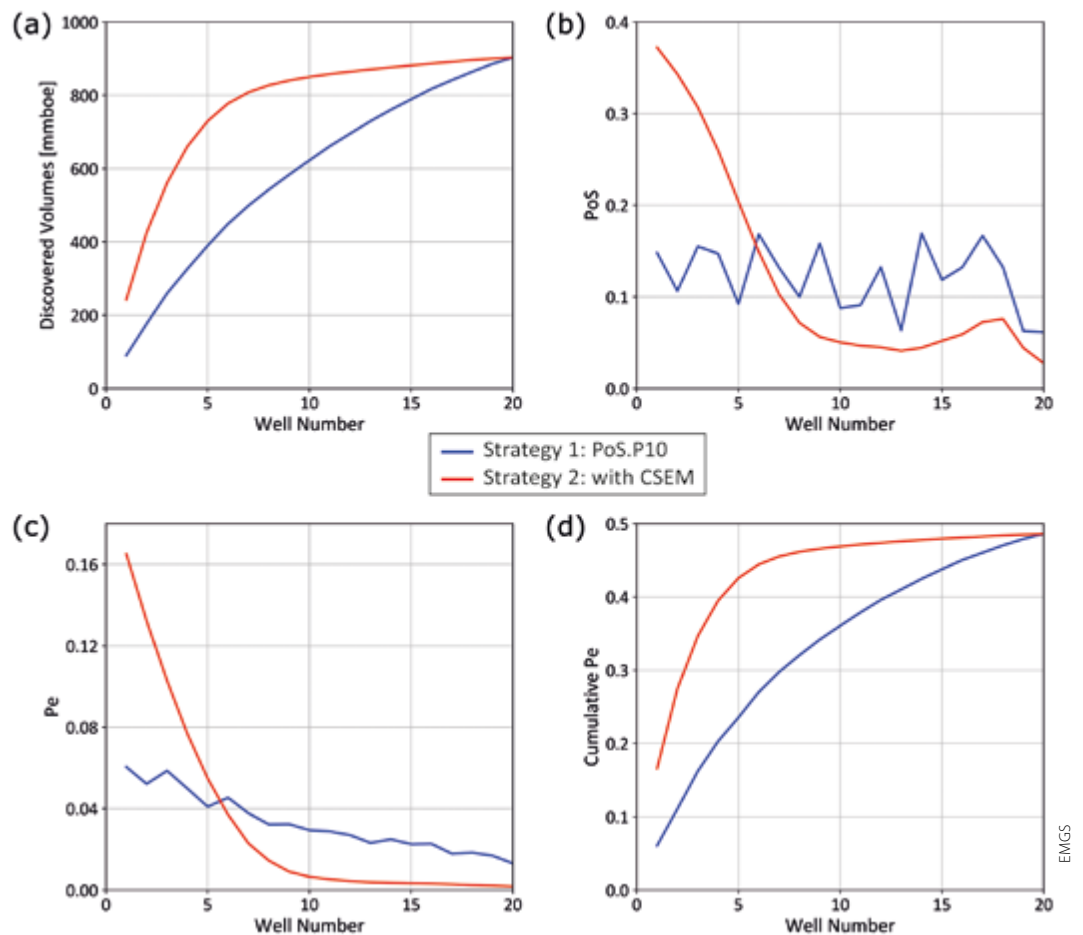

Figure 2: Mean outcomes for the two exploration strategies as a function of number of wells drilled, illustrating the performance improvement that can be expected with the addition of CSEM information.

the technology; however, we have shown that the resulting VOI can be extremely high, even when assuming an unrealistically high technology cost and high false-positive risk. The inclusion of embedded workflows for the re-evaluation of risk, volumes and reservoir quality only serves to further increase this potential value. Acquisition of CSEM even earlier in the exploration lifecycle can also lead to the potential for influencing commitment and bidding decisions. Combine the above values, and we see a bright future for CSEM data acquisition far earlier in the exploration process than was expected from its drill-or-drop origins.

References available online. ■

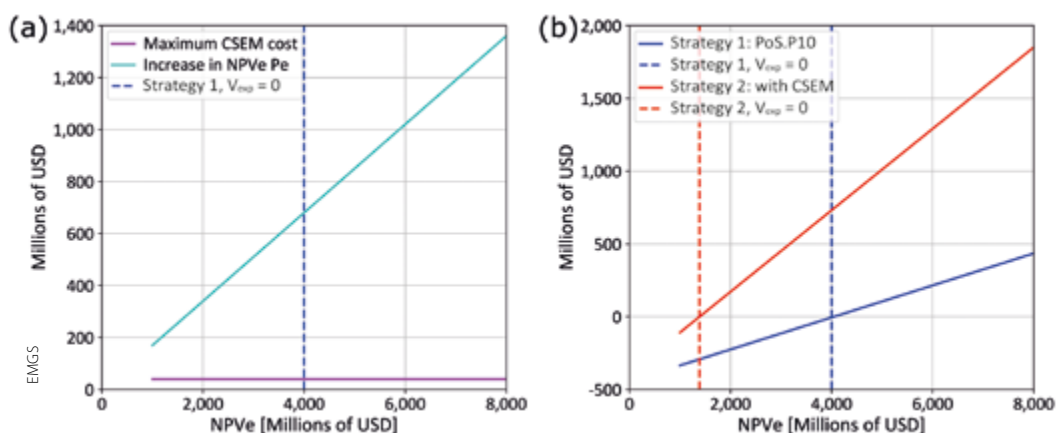

Figure 3 (a) value of CSEM information as a function of the venture NPV<sub>e</sub>, versus its cost, showing that, if applicable, the consistent use of CSEM for drilling sequence improvement outweighs its cost many times; (b) the consistent application of CSEM impacts the expected value of the exploration project, making it possible to improve the value of otherwise sub-economic exploration ventures.



# REGISTER EARLY AND SAVE UP TO US \$125

100 Years of Science Fueling 100 Years of Prosperity

## AAPG | SEG

### International Conference & Exhibition 2017

15-18 October  
ExCeL, London

Join us in London to learn, collaborate, network, and engage with industry peers and experts. At ICE 2017 you will meet geologists, geophysicists, and other petroleum industry professionals from countries around the world. Build your knowledge and skills, discover technology innovations, and interact with an array of professional geoscientists at ICE 2017.

[ICEEvent.org](http://ICEEvent.org)



# Time-Lapse Refraction Seismic II: Field Examples

MARTIN LANDRØ and LASSE AMUNDSEN

In the last edition we discussed the development of time-lapse refraction seismic as a complementary monitoring method. Here we look at some field examples.

*Scientific theory and its application to the growing needs of mankind advance hand in hand*  
Cargill Gilston Knott (1856–1922)

## Southern North Sea

The chalk fields in the southern part of the North Sea are good candidates for testing time-lapse refraction sensitivity. One example using the LoFS (Life of Field Seismic) data acquired over the Valhall field confirms this sensitivity (Zadeh et al., 2011). From Figure 1 we observe that the strong amplitude anomaly observed around 4,500m offset is shifted between the first (blue line) and the sixth (red line) LoFS surveys. The offset shift is of the order of 200m, and an additional offset shift is observed for the 8th LoFS survey (black line). This shortening of the critical offset is interpreted to be caused by velocity changes close to the reservoir.

Another potential use of the time-lapse refraction method is as a tool for the early detection of gas leakage or stress changes in the overburden. An example from an underground blow-out that occurred in well 2/4-14 in the North Sea is shown in Figure 2. By studying the refracted wave before and after the blow-out, we clearly observe a

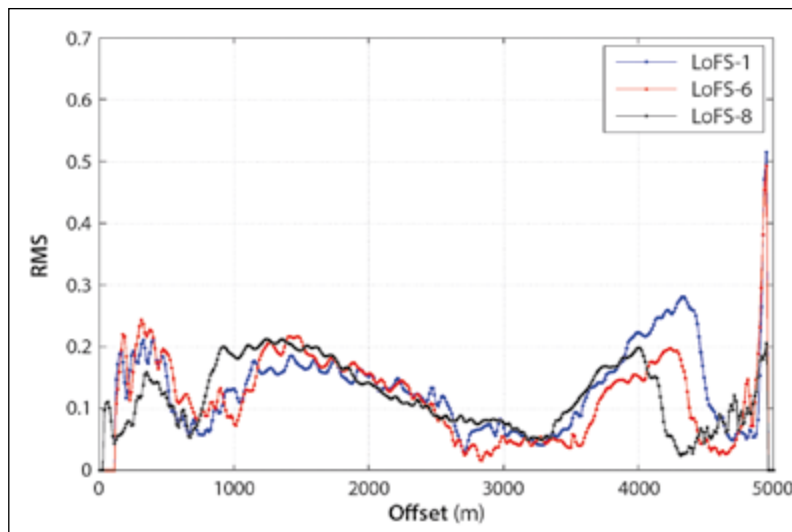

Figure 1: Field data example using LoFS data from Valhall: from survey 8 to survey 1 we observe a clear shift towards shorter offsets for the interpreted amplitude increase close to critical offset (4,000–4,500m). Figure from Zadeh et al., 2011.

time shift for these waves (Zadeh and Landrø, 2011). A more comprehensive analysis is shown in Figure 3, where time

*The Valhall field. Estimated recoverable reserves from the field at start of production in 1982 were 250 MMbo. Now, after 35 years of production, a total of 1,000 MMboe has been produced out of the original estimated 2.74 Bbo in place. The oil production rate in 2016 averaged ~44,000 boepd, and the field is expected to be producing until beyond 2040. The Valhall LoFS-project has now been running since 2003.*





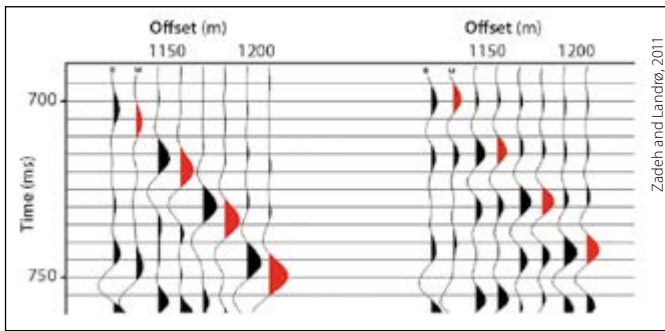

**Figure 2:** Observed time shift for the refracted wave close to the blow-out well (left) and similar display far away from the well (right). Black traces are before blow-out and red traces are after. Typical time shifts within the gas anomaly are of the order of 3-4 ms.

shifts are estimated along a 2D profile. We clearly observe that the time shifts increase to a maximum value of around 3–4 ms close to the blow-out well, and decrease away from it, as expected. Different colors in this plot represent different source-receiver offsets used in the time-lapse seismic analysis.

### Time-Lapse Refraction: Heavy Oil and Ice

A third example of time-lapse refraction was presented by Hansteen et al., 2010, where time shifts are observed close to a region where steam is injected into a heavy oil reservoir in Alberta, Canada. When the steam is injected, the stiffness of the rock is reduced, leading to a velocity decrease, which in turn leads to a corresponding increase in time shift. This was successfully observed in this field example.

A very different approach was used by Hilbich in 2010 where he exploited time-lapse refraction seismic tomography to study seasonal changes in the ground ice in the Alps. He concludes that the method is capable of detecting temporal changes in alpine permafrost and can identify ground ice degradation. A major strength of the method according to Hilbich is the high vertical resolution potential and the ability to discriminate phase changes between frozen and unfrozen material over time. A significant limitation is the low penetration depth due to strong velocity contrasts between the active layer and the permafrost table.

### Time-Lapse Refraction Radar

Since 2003 several of the major fields offshore Norway have been equipped with permanent receiver arrays at the seabed. The Valhall LoFS-project has been running since then, providing useful data for the operator. At a later date the Ekofisk, Snorre and Grane fields installed similar permanent monitoring systems. The technologies of the systems have been different, but the key concept of semi-continuous monitoring of the field during production has been the same. Typically, these fields are monitored more frequently using this method than when conventional time-lapse seismic surveys are used. A frequency of one to two surveys a year is normal.

Permanent arrays can also be used to monitor micro seismic events, earthquakes, vessel noise, drilling noise and noise from ship traffic. Another potential use of a

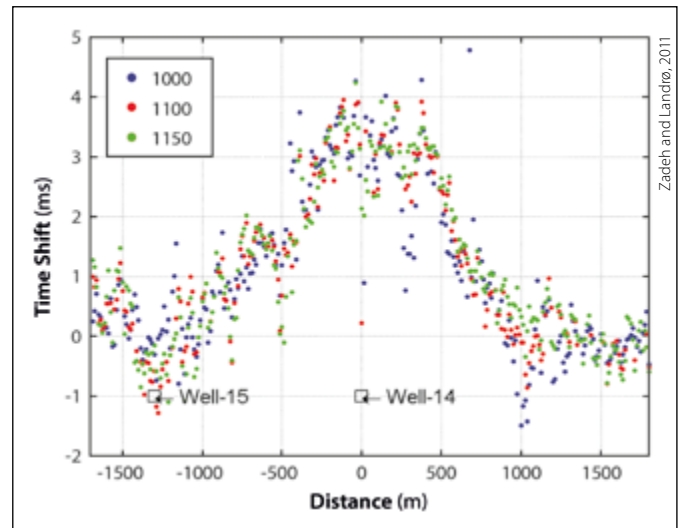

**Figure 3:** Estimated refraction time shifts for three offsets close to the blow-out well (14) – a positive time shift of up to 4 ms is observed.

permanent array is to deploy a simple source firing from the platform (a single gun or a small cluster of airguns may be used for this purpose), and then record the refracted seismic signals from shallow (and if possible, deeper) layers, as illustrated in Figure 4. The time interval between each shot at the platform might be once a month, once a day

**Figure 4:** Time-lapse refraction radar. Outline of the Grane field (color bar shows depth to the reservoir), which is equipped with a permanent array at the seabed, and if we assume that a seismic source is fired every day at the platform, the refracted signals may be detected at the seabed by the array, and hence it is possible (at least in theory!) to construct a time-lapse refraction radar, sweeping over the field.

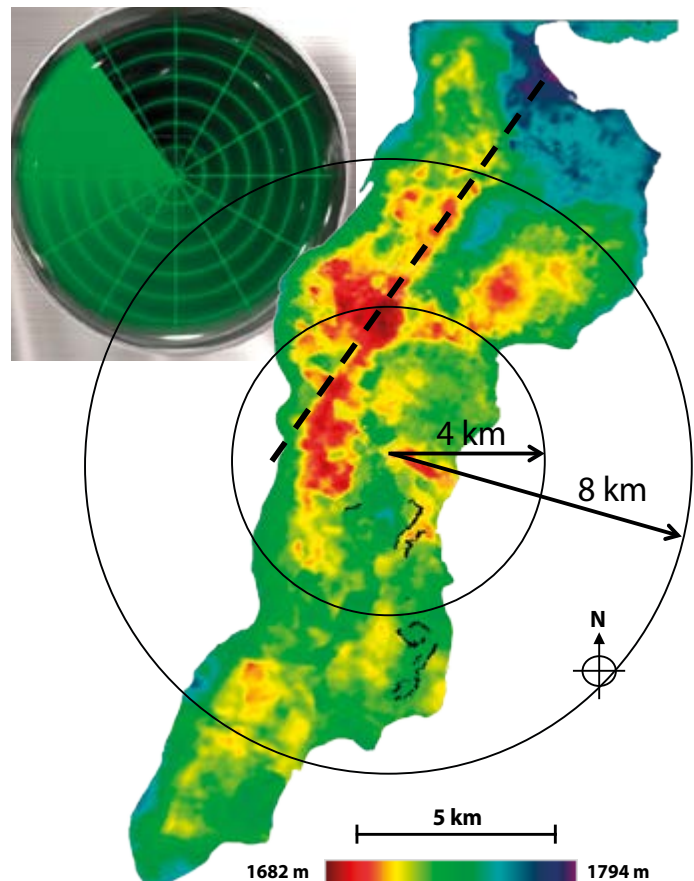

## Recent Advances in Technology

or even once every hour if one wants to follow a specific event. Under normal conditions, this radar system will not detect any changes; the data from one survey is more or less identical to the one from the previous one apart from noise. A detection system needs to be developed to register abnormal signals when they occur, and how they develop over time. The potential strength of this method is that it is cheap (assuming that the cost of the permanent array is already paid) and the processing or analysis of the data is also fairly straightforward. Weaknesses are related to practical issues regarding firing a seismic airgun from a platform, and to the fact that it is challenging to locate an anomalous event at depth. The x and y coordinates of an event are easily and very precisely determined since the source and the receiver positions are known. Depth can be estimated roughly from seismic modeling. So far, this has not been tested at any field, and therefore there is a chance that refraction radar will remain what it is today: an idea.

### The Future of Time-Lapse Refraction

At present time-lapse refraction is not well established as a 4D technique, but the few examples presented so far illustrate that the technique has potential. One weakness is that it is hard to map the time-lapse anomalies precisely in depth. Fortunately, full waveform inversion techniques have developed significantly over the last decade (Virieux and Operto 2009, Sirgue et al., 2009). A few examples of this technique have also been presented for 4D applications (Routh et al., 2009). Therefore, there is hope that time-lapse refraction methods might develop into a more precise and accurate technique. It is important to underline the fact that if 4D refraction is used as a tool for identifying shallow gas leakage, the critical issue is to detect and locate approximately where the leakage occurs. Detailed and accurate mapping of the 4D anomaly is not crucial.

*References available online.* ■

### A Short History of Seismic Exploration

**1846:** Robert Mallet publishes the article 'On the dynamics of earthquakes', and receives a grant of £150 to go to Padula in Italy to record and investigate the damages after the earthquake.

**1888:** August Schmidt uses traveltimes versus distance plots to determine seismic velocities.

**1899:** Cargill Gilston Knott describes and explains propagation, refraction and reflection of seismic waves at subsurface boundaries. He derives reflection coefficients for non-vertical rays which are essentially the same equations that we refer to today as the Zoeppritz equations, which were published 20 years later, in 1919. Knott spent several years in Tokyo and received the Order of the Rising Sun.

**1910:** Andrija Mohorovičić identifies distinct phases of P- and S-waves on traveltimes plots from earthquake data. He interpreted them as refractions from a boundary between low and high velocity layers. This boundary, which separates the earth's crust from the mantle below, is the Moho.

**1916:** Refraction seismic is used to determine the location of heavy artillery by studying the refracted waves generated by the recoil when the guns were fired. Both the Allies and Germany developed this method, and Ludger Mintrop was especially active in this work; he patented a portable seismograph in 1919.

**1919–1921:** K.C. Karcher carries out the first seismic reflection survey, based on pioneering work done in 1913 by Reginald Fessenden.

**1921:** Ludger Mintrop founds 'Seismos Gesellschaft' with the ambition of using seismic refraction methods to explore and map salt domes acting as traps for hydrocarbons.

**1924:** The Orchard Salt Dome in Texas is discovered by using refraction seismic and the equipment of Seismos.

**1927:** Seismic reflection is used routinely for hydrocarbon exploration.

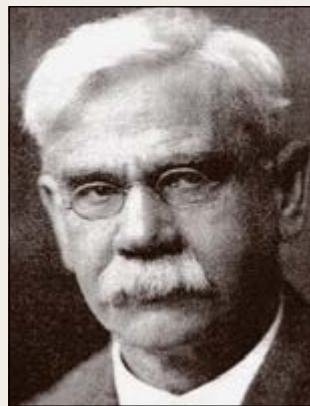

*Cargill Gilston Knott (1856–1922) was the first to explain refraction.*

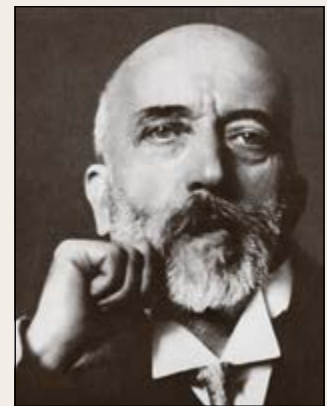

*Andrija Mohorovičić (1857–1936) was a Croatian meteorologist and seismologist.*



*Ludger Mintrop (1880–1956) developed the portable seismograph and used seismic refraction to map salt structures.*



# Featuring highly anticipated Technical Gurus at APGCE 2017



**Prof Paul Tapponnier**

*Professor,  
Earth Observatory of Singapore,  
Singapore*



**Prof Robert Hall**

*Professor and Director of SE Asia Group,  
Royal Holloway University of London,  
United Kingdom*



**Ian Longley**

*Geologist/Director,  
GIS-PAX Ltd.,  
Australia*



**Dries Gisolf**

*Director,  
R&D, Delft Inversion,  
Netherlands*



**Prof Richard Swarbrick**

*Managing Director,  
Swarbrick GeoPressure Consultancy Ltd.,  
United Kingdom*



**Prof Don Lawton**

*Director,  
Containment and Monitoring  
Institute at Carbon Management,  
University of Calgary,  
Canada*

**REGISTER NOW**

at [www.apgce.com](http://www.apgce.com)

## ASIA PETROLEUM GEOSCIENCE CONFERENCE & EXHIBITION (APGCE) 2017

*Collaborative Solutions. Sharing Success.*

**20-21 NOVEMBER 2017**

Kuala Lumpur Convention Centre, Malaysia



Hosted by:



Event Organiser: In collaboration with:



[apgce@icep.com.my](mailto:apgce@icep.com.my)



@APGCE2017



@apgce2017



# Regional Play Types in the Mexican Offshore

TGS' Gigante is the largest 2D multi-client seismic survey in the world. It comprises 186,250 km of long offset data (streamer length 12 km, record length 16 sec) spanning the entire Mexican Gulf of Mexico (GOM), and ties to datasets in the US GOM. An additional 5,700 km covers the unexplored Caribbean coast of the Yucatan Peninsula. Gigante provides continuous coverage across the entire GOM, linking known petroleum systems to vast underexplored areas of the basin as a springboard for new exploration.

The Gigante seismic survey is complemented by potential field data and over 600,000 km<sup>2</sup> of multibeam data with coring and geochemical analysis. This provides the industry with a comprehensive database with which to evaluate the petroleum systems of the entire GOM. TGS' interpretation study utilizes all available datasets and aims to deliver a complete regional tectono-stratigraphic interpretation of the Mexican offshore.

A complex tectonic history has resulted in numerous structural provinces throughout the Mexican Gulf of Mexico, each with characteristic structural styles and sedimentary sequences. This article presents an introductory discussion on the structural styles and play types that are witnessed in the seismic data and provide insights on each geological basin.

*View of the northern Salina del Istmo, at the foot of the Campeche Escarpment, showing a thick pre-salt syn-rift section overlain by salt and rotated fault blocks of Upper Jurassic – Early Cretaceous sequences.*

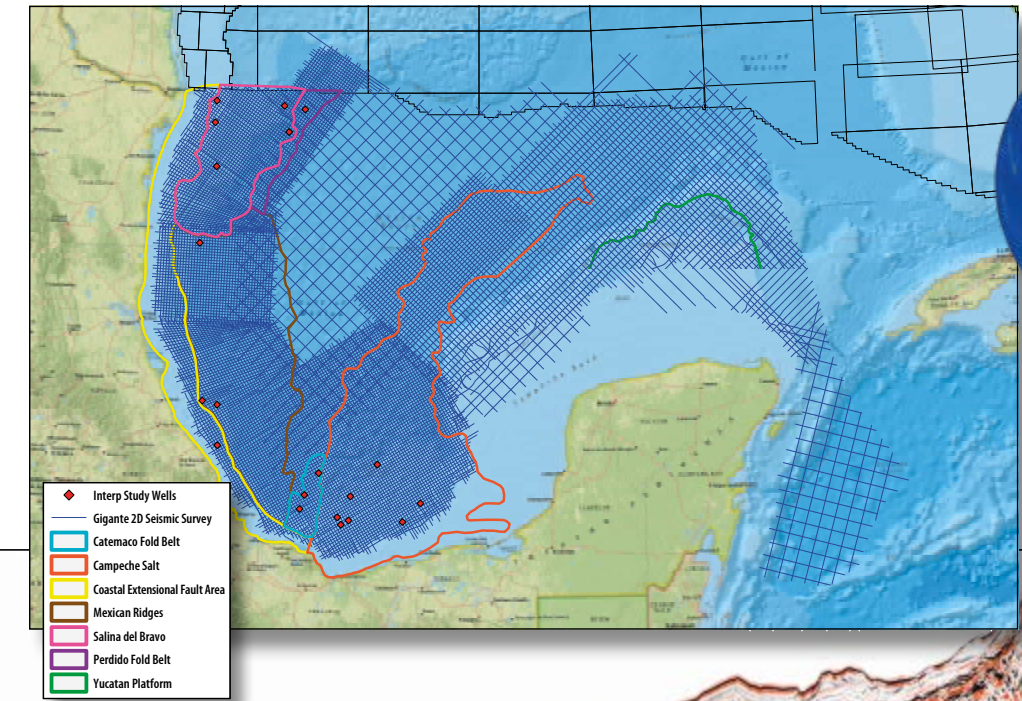

Map showing the extent of the Gigante seismic in relation to the main geological features of the Mexican Gulf of Mexico.

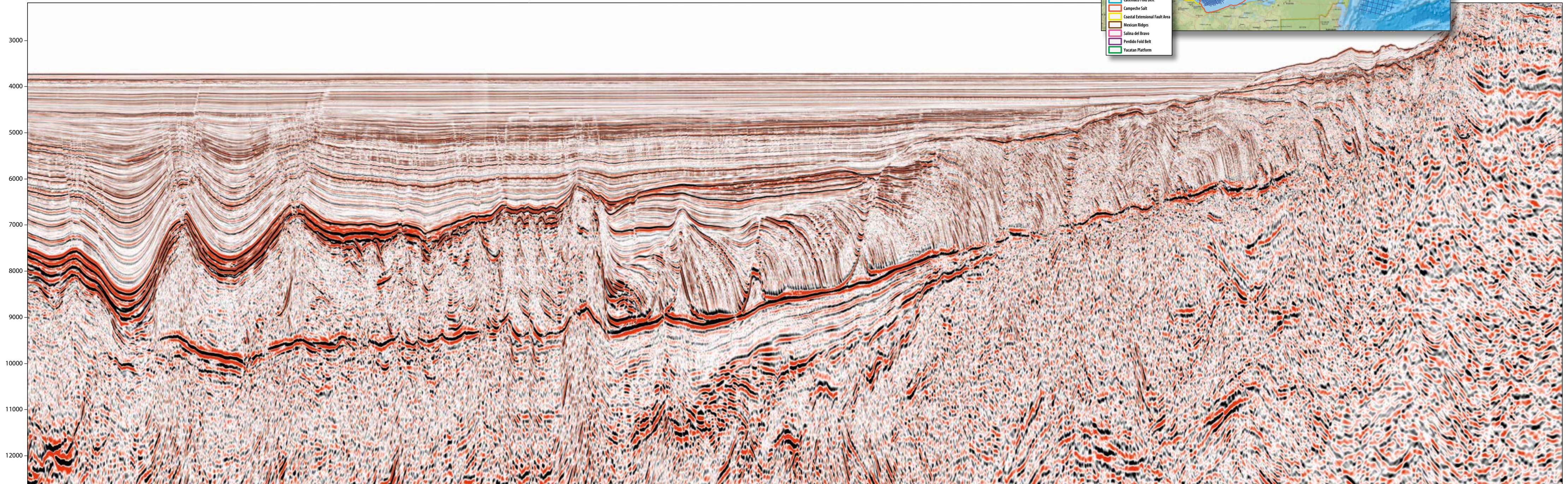



# Structural Styles and Regional Play Types

New seismic data has revealed a wealth of untested opportunities in the Mexican offshore.

**CIAN O' REILLY, JAMES KEAY, ALEX BIRCH-HAWKINS, DUNCAN BATE and JENNIFER HALLIDAY; TGS**

The geological evolution of the Gulf of Mexico (GOM) began with Late Triassic rifting followed by Late Jurassic oceanic spreading and then transition to a passive margin. Thick Middle Jurassic salt deposited in rift basins began to move by the Late Jurassic. A stable tectonic setting developed from the Late Jurassic, characterized by carbonate deposition on shallow water structural highs fringing the subsiding oceanic basin. Large Late Cretaceous to Miocene clastic sediment inputs related to events like the Laramide and Chiapas orogenies resulted in gravity sliding and high amplitude fold belts along the western flanks of the basin. Complex contractional terrains in the southern GOM are overprinted by halokinesis, which also sets up deepwater play possibilities in the Salina del Istmo.

The Gigante regional survey is ideally suited to creating a catalog of structural styles, depositional characteristics, and trap and play types for each of the Mexican GOM (MGOM) structural provinces. Seismic integration with potential field data helps constrain the tectono-stratigraphic framework and provides insights to deep structure and the extent of oceanic – continental crust boundaries. Several major structurally defined provinces are defined in the MGOM (see inset map on seismic foldout).

Sedimentary basins immediately offshore the eastern and southern coasts of Mexico are dominated by belts of extensional normal faults, ranging in age from Triassic – Jurassic syn-rift faults to listric normal growth faults of Tertiary to Recent age. Fold belts lie outboard of the extensional belts, and may be linked to them by detachment surfaces in overpressured shales or may be distal expressions of onshore orogenies. Major salt provinces in the Salina del Bravo and in the Salina del Istmo form the outermost structural provinces before we pass into the Abyssal Plain. Industry interest is currently focused on these basins following the recent announcement of the CNH R02-L04/2017 bid round.

The Yucatan Platform, with no fringing extensional or contractional belts, forms a distinct area whose major structural influence was the

Chicxulub impact which resulted in breccia deposits and fracturing of Mesozoic carbonates. Combination and stratigraphic traps may be more important than structural traps in the Yucatan Platform and in parts of the Yucatan Escarpment.

## Salina del Bravo

The Salina del Bravo province lies between the offshore Burgos Delta (characterized by extensional fault block geometries) and the Perdido Fold Belt and has transitional boundaries with them. It has two sub-zones: a western mini-basins zone and an eastern sub-salt zone. The listric normal growth faults seen in the adjacent Burgos Delta detach into Eocene to Oligocene shales. A range of structural styles, controlled by mobile salt and by salt- and shale tectonics, reflects regional shortening of the thin-skinned gravity-driven linked extensional-contractional system that extends from the Burgos Basin to the Perdido Fold Belt. The main structural features developed in the Salina del Bravo area are salt (and/or mud) diapirs and walls. Onlap-type traps with updip pinchout against salt are common. Anticlinal structures (whether turtles or salt-cored folds) are also likely trap types. An example is shown in Figure 1. Figure 2 shows an undrilled anticlinal closure in Paleocene – Eocene Wilcox sands in the sub-salt zone.

*Figure 1: Structural styles in the Salina del Bravo (mini-basins zone) (PSTM). Vertical fluid escape features are visible on the seismic, together with amplitude anomalies in Middle and Late Miocene sands at the well location.*

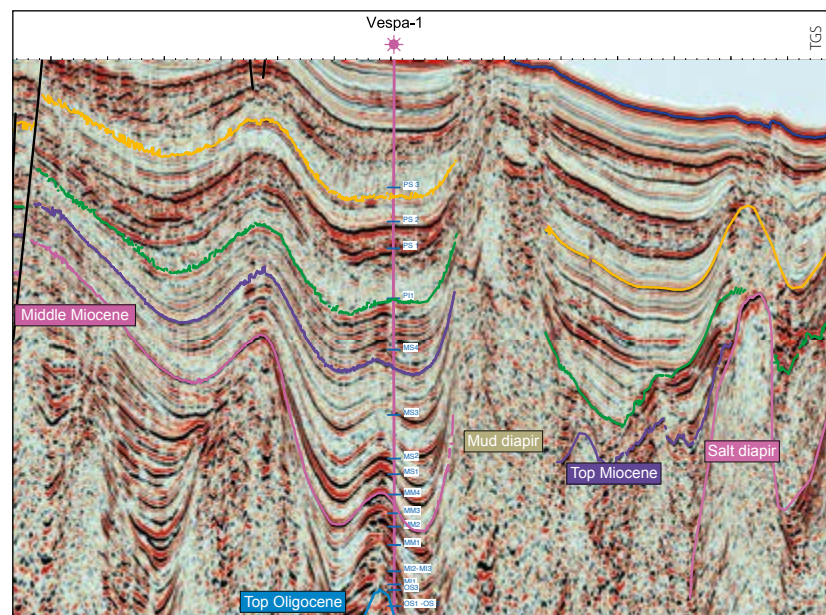



## Perdido Fold Belt

The cross-border Perdido Fold Belt is bounded by the Salina del Bravo to the west and the Abyssal Plain to the east. The north-east to south-west trending anticlines were developed during Oligocene contraction, as evidenced by the prominently developed Late Oligocene unconformity characteristic of the fold belt and the fact that the Lower Miocene, Oligocene and Eocene strata are often missing at the crests of anticlines (e.g. at Trion-1). The development of the Perdido Fold Belt is still contentious; however, most interpretations are some variant on detachment folds (possibly salt-cored) associated with steep reverse faults or kink bands.

## Quetzalcoatl Extensional System and the Mexican Ridges

In the south, offshore the Tampico-Misantla Basin and the Tuxpan Platform, the passive continental margin is characterized by a series of normal growth faults known as the Quetzalcoatl Extensional System (QES). The QES is a zone of listric normal growth faults linked downdip through detachment surfaces in overpressured shales with an approximately 500 km long downdip series of long and narrow coast-parallel anticlines (the Mexican Ridges) along the continental shelf and slope (Figure 3). Trap types in the QES are rotated fault blocks and rollover anticlines. Fields in the QES include Lankahuasa and Kosni.

No fields have yet been developed in the Mexican Ridges (MR) which are high amplitude, low half-wavelength folds that have been building since the Oligocene. The MR folds range up to 170 km long and 8 km in width and are often prominently developed at seabed.

## Catemaco Fold Belt

The Catemaco Fold Belt (CFB) lies between the Mexican Ridges and the Salina del Istmo provinces. The CFB is characterized by north-east to south-west aligned anticlines, thrust faults and fault-bend folds which were created during Late Miocene-Pleistocene contraction due to the interplay of the Chiapaneco orogenic event and gravitational contraction of the Mexican Ridges. Several of these folds have yielded gas discoveries. Unlike the MR, the Catemaco Fold Belt anticlines (other than the Yoka Anticline at the edge of the salt) have little to no expression at sea floor.

## Salina del Istmo /Campeche Salt Basin

The offshore Salina del Istmo/ Campeche Salt Basin is bounded to the west by the Catemaco Fold Belt, to the east by the Yucatan Platform and to the south by the Sureste

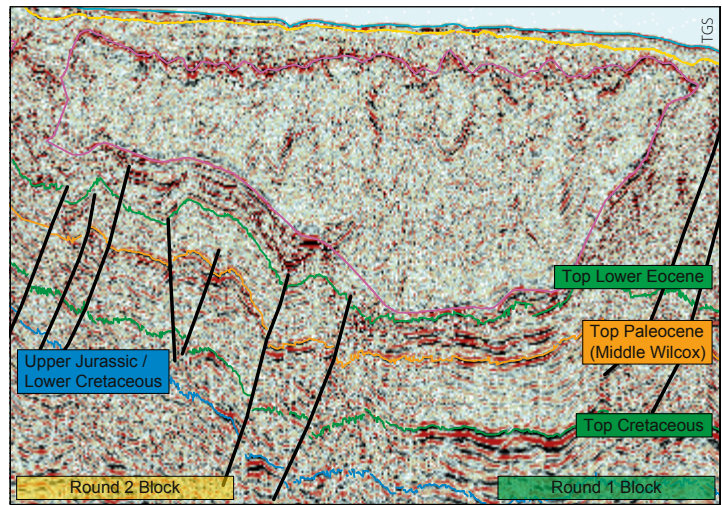

**Figure 2: Undrilled Wilcox Sands lead in the Salina del Bravo (sub-salt zone) (PSDM). Upper and Middle Wilcox sands are present in anticlinal closures with possible migration routes from Upper Jurassic source rocks along steep basement-involved reverse faults.**

Basins (not discussed here). To the north it passes into the Abyssal Plain, where stretched continental/transitional crust passes into oceanic crust. Above the basement, Pre-Triassic red beds and Early to Middle Jurassic syn-rift sediments are overlain by Callovian salt and Late Jurassic to Recent post-rift clastics and carbonates (as seen in the seismic foldout). Salt motion, active since the Late Jurassic, allied with major structural events such as Late Miocene folding and Pliocene-Pleistocene gravitational extension, has resulted in a wide range of proven structural and combination traps in this province, such as those recently tested by Sierra (Zama-1) and ENI (Amoca-2). The syn-rift extensional traps featured in the seismic foldout in this article remain an untested opportunity in the deep offshore Salina del Istmo. ■

**Figure 3: Structural styles in the Quetzalcoatl Extensional System (QES) and the Mexican Ridges (PSTM). This figure shows a possible Cretaceous reef structure (edge of the Faja de Oro), listric normal growth fault blocks and rollovers (as tested in the Lankahuasa and Kosni fields) and Mexican Ridges anticlines with amplitude anomalies and flat spots in Miocene and Pliocene sands in the fold crests.**

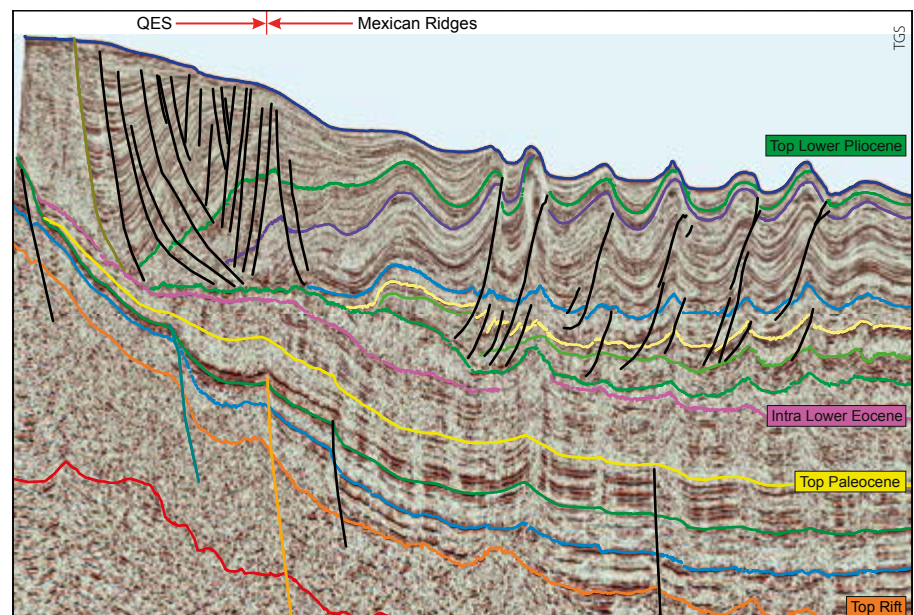



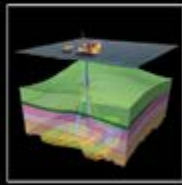
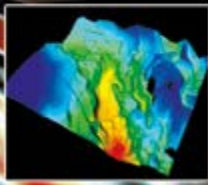

The Geological Society

*-serving science & profession*

Corporate Supporters:



Convenors:

**Gro Haatvedt**  
Aker BP

**Ian Wilson**

**Kitty Hall**  
Petroleum Group

Confirmed Speakers from:

**Aker BP**  
**Azinor Catalyst**  
**Badley Ashton**  
**Dana Petroleum**  
**Geus**  
**Hansa Hydrocarbons**  
**Hurricane Energy**  
**Imperial College**  
**Maersk Oil**  
**NPD**  
**OGA**  
**PGS**  
**Statoil**  
**TNO**  
**University Aberdeen**  
**University Durham**

Event Sponsors:



**Registration Open**

# Cross-border Exploration between UK & Norway – Comparisons, Contrasts and Collaborations

**27-28 November 2017**

The Geological Society, Burlington House, Piccadilly, London

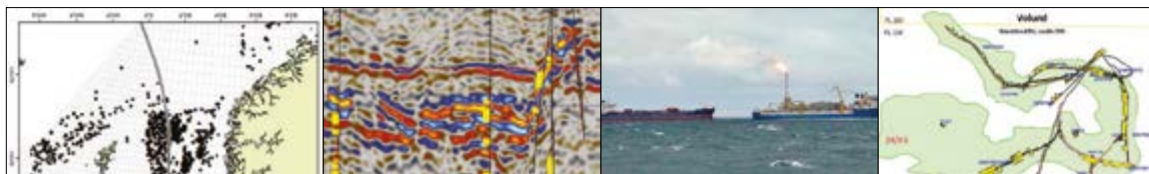

Can additional high value barrels be discovered through improved collaboration between UK and Norway? The objective of the conference is to enhance technical understanding of the status of key plays on each side of the border, to establish points of similarity and difference in both activity and success, and to highlight new opportunities. Important recent discoveries on either side of the border will be examined and the conference will seek to establish where new plays in one country have

not yet been understood or exploited across the border. Key note presentations will be made by leading figures from both Norway and UK.

This two day international conference will bring together explorationists from UK, Norway and other European countries with the following themes:

- Play opening discoveries as yet unexploited cross border
- Differences in how competence is organised and technology adopted
- Examples of specific play knowledge being exploited cross border
- Challenges on median line including data continuity and differences in nomenclature
- How to build a geology-without-borders view
- Issues for service industry
- Differences in exploration performance
- Danish and Dutch (and other) cross border examples
- Impact of regulatory and fiscal frameworks

**For further information or to register please contact:**

Sarah Woodcock, The Geological Society, Burlington House, Piccadilly, London W1J 0BG.

Tel: +44 (0)20 7434 9944. Or visit the conference webpage: [www.geolsoc.org.uk/PG-Cross-Border](http://www.geolsoc.org.uk/PG-Cross-Border)



*At the forefront of petroleum geoscience*

[www.geolsoc.org.uk/petroleum](http://www.geolsoc.org.uk/petroleum)

# The Future is at the Bottom of the Ocean

Ocean bottom seismic (OBS) has been gaining market share over high-end streamer acquisition. One of the ground-breaking technologies within OBS acquisition is Magseis' Marine Autonomous Seismic System.

## PETTER STEEN-HANSEN, Magseis

Until recently, 90% of the seismic acquired for the oil and gas industry has been through traditional streamer surveys. Only 10% was obtained through ocean bottom seismic (OBS), which has been struggling with inefficient technologies, static acquisitions and a limited market, all leading to higher cost, which historically has been the greatest barrier for a much wider adaptation of the technology. However, the quality of OBS data in comparison to other seismic is undisputed, and demand for full azimuth seismic is increasing, due to its improved imaging in areas

with reservoir complexity, gas clouds, in pre- and sub-salt basins and for infrastructure and monitoring purposes. With major technological enhancements now being developed to overcome the traditional barriers, OBS is slowly gaining market share. Norwegian company Magseis believes that its proprietary Marine Autonomous Seismic System (MASS) is at the forefront of this technology.

### Next Generation OBS

Magseis' OBS acquisition using MASS is based on the principle of autonomous sensor capsules inserted into an

optimized steel cable, and is therefore all about the ability to handle large amounts of equipment effectively. The company realized that if it could increase the number of nodes deployed on the seabed, it would be possible to dramatically increase efficiency and reduce cost. Inspired by the miniaturization of technology in the mobile phone industry, the company has developed the smallest and lightest sensor in the marketplace, which weighs a mere 8 kg, yet still provides the excellent sea floor contact needed to obtain top quality multicomponent data. With such an ultra-compact unit, there is now no limit

*An ultra-compact OBS node within the casing on the wire being deployed close to an installation at the Bokor Field, Malaysia.*





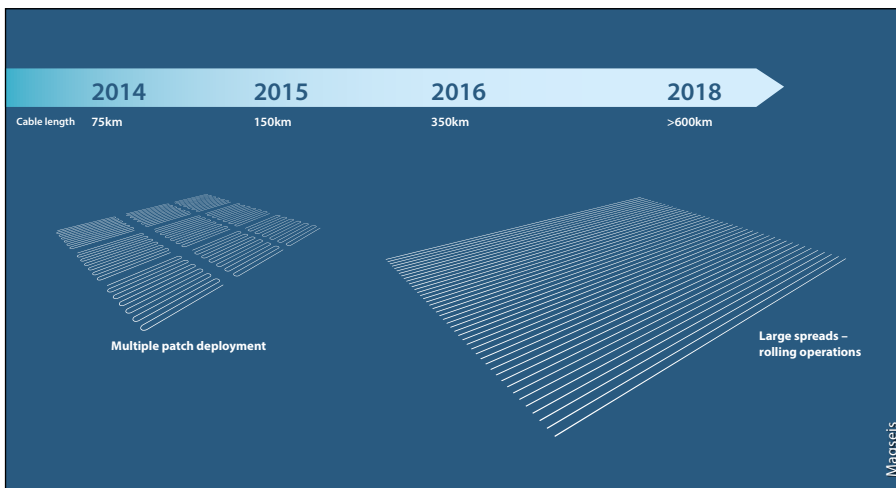

**Larger OBS spreads are driving substantial cost reductions.**

on the number of sensors which can be deployed in any survey. In combination with fully automated handling systems and the use of robots, improved node management logistics is providing increased efficiencies, low failure rates and safer operations..

This development is a step forward reminiscent of the way in which efficiencies in towed streamer seismic exploded when that technology moved from 2D to 3D and began towing up to 20 cables, thereby covering much larger areas than had previously been thought possible. With the MASS system the cable can be deployed and recovered at higher speeds and in much larger quantities than previously possible, so greater numbers of sensors can be placed on the seabed more efficiently than before, shortening survey times, meaning that overall productivity is dramatically increased.

In tandem with the reduction in size of the nodes, there has been an increase in the size of OBS survey spreads. In its first commercial operation using the new nodes, for Statoil in Norway in 2013, Magseis deployed about 75 km of cable in a 'multiple patch' deployment, using 3,000 nodes. By comparison, it is currently operating more than 350 km of active cable in a much more efficient 'rolling configuration' for Saudi Aramco in the Red Sea, while preparations are ongoing for introducing its next cable crew with 600 km of cable and 6,000 nodes, to be delivered in 2018. There are further plans to increase capacity to 1,000 km of cable and 10,000 nodes.

### One Technology – Multiple Applications

The MASS node is depth rated from 0-3,000m, which means that the same sensor can be used across all water depths. Because the node is compact and robust, it has a versatile operating platform, and can be deployed by different vehicles. To complement the large scale cable operations, Magseis has developed a modular unit. MASS Modular is a mobile and scalable set-up which maintains the fully automated handling system, by placing the robots and node management system inside offshore certified containers. This system can be fitted on to any kind of vessel and be deployed by using ROV's or other techniques such as rope for shallow water and transition zone operations.

The company believes that the modular aspect of MASS is groundbreaking because of its full automation

and scalability. The miniaturized nodes take up very little space, with 800 of them fitting into a 10 foot container, so the operation can be tailored to fit any requirement. Whether deploying a few hundred nodes in combination with a streamer survey to infill around platforms or several thousand nodes on a large scale operation, the footprint and logistics are almost identical. The modular nature of the system makes it very flexible and means that it can be sent to different corners of the world at a fraction of the cost of transiting a vessel with equipment and personnel. In addition, by maintaining the full automation inside only a few containers and letting the robots work like clockwork, the result is an extremely competitive portable solution.

The modular system also means that it is possible to deploy the nodes, not just by cables, but also in different ways for different purposes, including using remotely operated vehicles (ROVs). Such vehicles are limited by how much weight they can carry, and so it is obvious that a lighter weight node means more of them can be deployed at a time, thus significantly increasing the efficiencies. ROV deployment is especially important within the 4D and hybrid permanent reservoirs management market, because of the positioning accuracy required for time-lapse monitoring. By using vessels of opportunity, for instance those operated by a client on a large oilfield, Magseis has identified a method of working in a smarter way with its clients in order to reduce costs.

**One of the docking robots onboard handling control units and battery units.**



### Revolution in Ultra-Deepwater

This modular system also extends to deepwater operations which have a particular reputation for being time-consuming and costly. The small and compact node sensor technology attracted Shell Technology to enter into a joint development project with Magseis for a specialized ultra-deep water deployment vehicle with 4D positioning accuracy. The system was field-tested with great success in late summer 2016 and proved that deployment in ultra-deepwater could be revolutionized with both significantly faster placement and retrieval of nodes and increased sampling. This could be a game-changing technology which will not only compete with current OBN (Ocean Bottom Node) projects, but has the potential to overtake the large multi- and wide-azimuth towed streamer market.

The full range of capabilities of the MASS system, including in deepwater, were tested earlier this year with a survey for Saudi Aramco in the Red Sea, where water depths in the survey area varied from 1,000m to the transition zone and in some cases over dry land in the form of small islands, all on the same receiver line. Despite the challenging environment and rugged seabed the survey has been executed ahead of schedule and with very high data quality.



*The modular MASS being lifted onboard, with an ROV in the background, between the vessel and the truck.*

### Source Isolation

By deploying these large spreads with increased efficiencies, challenges to OBS are essentially moving away from being receiver bound to source bound. It is critical for productivity to ensure a balance between the time it takes to handle the nodes and time taken with source effort. Therefore, having tackled issues surrounding the receivers involved in OBS surveys, Magseis has now turned its attention to improving efficiencies in the source technology. Earlier this year the company signed an exclusive technology agreement with Seismic Apparition GmbH, which specializes

in advanced seismic data acquisition, processing and imaging services, to jointly develop and implement a new innovative technology that will reduce operational time in OBS surveys by using a technique known as source isolation.

Unlike existing techniques which tend towards increasing the number of sources, source isolation delivers full-fold, full-length data from isolated sources by using the science of signal apparition, combined with proprietary methods for data acquisition and reconstruction, to isolate a set of quasi-parallel adjacent shots into areas that contain no signal. This unique

*The ultra-deepwater node deployer ready to be lowered and detached from the crane, after which it will be controlled by the umbilical as it is submerged.*





approach addresses many of the shortfalls of conventional simultaneous or dithered source techniques, since there is no need for shots to be sequenced, and each individual source does not have to be physically distant from the others, as it works with multiple sources that are close together. This unleashes the potential for dense source spacing, which provides the same impact on cross-line sampling as tight receiver line spacing.

The combination of improved source efficiency through simultaneous shooting from a single vessel, together with better source sampling when compared to conventional technologies, offers the unique prospect of acquiring reservoir quality data from efficient exploration configurations. This could result in a reduction in the cost of OBS data acquisition of 30 to 50%. Source isolation will be applicable both for reservoir 4D projects and more regional surveys.

### Still Niche?

Although OBS is known to provide superior image quality, addressing cost efficiencies is vital in order for the technique to come into the mainstream. Through the development of ultra-compact nodes, a fully automated handling method with superior logistics, an efficient modular system for storage and deployment and improved source technology, Magseis believe they are enabling step-changing efficiencies in OBS acquisition. The resultant reduction in the price of OBS surveys will increase cost-competitiveness, allow for a broader range of applications, from exploration through to monitoring, and will expand the number and size of fields for which the system is applicable.

So is this still a niche market? The market share for the technology has now moved to 20% and is rising steadily; perhaps ocean bottom seismic has finally become standard. ■

*The author holding one of the ultra-compact nodes.*



# ENVOI

delivering energy opportunities

ENVOI specialises in upstream acquisition and divestment (A&D), project marketing and portfolio advice for the international oil and gas industry.



### ACTIVE PROJECTS

#### GABON

(Offshore exploration)

#### GHANA

(Offshore exploration)

#### TUNISIA

(Onshore exploration)

#### KAZAKHSTAN

(Onshore appraisal/development)

#### CENTRAL ASIA

(Onshore production/exploration)

#### UK: EAST MIDLANDS

(Onshore appraisal/development)

#### UK: NORTH SEA

(Offshore exploration)

#### ISRAEL

(Onshore exploration)

#### COLOMBIA

(Onshore exploration)

#### PARAGUAY

(Onshore exploration)

VISIT [WWW.ENVOI.CO.UK](http://WWW.ENVOI.CO.UK)  
FOR MORE INFORMATION

# A New Era For LNG

**Low energy prices provide a challenging environment for new liquefied natural gas projects.**

**BILL HOWE, Gasconsult Ltd**

*Prelude, Shell's giant floating liquefied natural gas facility, is the largest floating structure in the world. Built in South Korea, in late June it started its journey to north-west Australia, where it is expected to produce at least 5.3 MMt/y of liquids.*

The 2015 United Nations COP21 meeting in Paris saw world leaders finally commit to measures to limit global warming. Part of the solution, as an interim measure pending greater proliferation of renewable energy, is the increased use of natural gas as an alternative to coal and oil, in order to mitigate the ever-increasing atmospheric CO<sub>2</sub> levels that are a major contributor to global warming. Use of gas instead of coal for power generation, as an example, reduces CO<sub>2</sub> emissions by 60%. This in part arises from the chemical characteristics of the fuels (a higher carbon content in coal) and in part from the significantly higher energy efficiency achieved by combined cycle gas turbine power generators when compared to their coal equivalents.

As well as carbon, there are other environmental drivers at play, including sulfur, nitrogen oxides and particulate emissions (see graph, top of page 47). By any environmental measure gas is superior to all other fossil fuels, which has led to increasing interest in its use

as a transportation fuel for marine, trucking and railroad applications.

## **LNG Supply and Demand Growth**

The world has approximately 6,600 Tcf of conventional gas reserves, adequate for a little over 50 years supply at the current global gas demand of 123 Tcf per year. Whilst pipeline transmission of gas is the norm, approximately 10% of global gas consumption is supplied by liquefied natural gas (LNG), which is transported to market at minus 161°C in specially designed ships. The liquefaction route, which reduces the gas volume by a factor of 600, is necessary for remote gas reserves where pipeline costs are prohibitive, or where geopolitical issues preclude security of pipeline supply.

A 2013 report from the US Geological Survey estimated that about 40% (2,611 Tcf) of the world's proven reserves was effectively stranded, implying that monetization of those reserves would be through LNG. Of the total stranded gas, some 1,529 Tcf are





located onshore and 1,082 Tcf offshore. The offshore reserves have initiated a move to ship-based liquefaction plants (floating LNG, or FLNG).

LNG sales volumes have progressively risen to meet increasing demand for gas and LNG is forecast to meet the bulk of future increases in demand. Growth projections prompted a major commitment to new LNG plants; the period 2011 to 2015 saw final investment decisions on over 100 million tonnes per year (MMt/y) of new LNG capacity. Such is the level of new construction that excess LNG capacity is forecast until the early part of the next decade. Furthermore, the new builds have been characterized by increasing complexity, higher plant capacities, and high energy efficiency and co-product value realization. These factors and project cost over-runs have seen new build costs escalate from \$200 per annual tonne of capacity to more than \$1,200 per tonne over the past decade. Recent LNG plants have capital costs upwards of \$30 billion, massive investments by any measure and representing high financial risk even for the biggest corporations.

### The Energy Price Impact

The fall in the oil price has put the LNG industry under financial pressure, the more so when considering the high capital cost of recent new builds and the projected overhang in liquefaction capacity. LNG prices have fallen to 50% of pre-oil price crash levels, severely impacting project returns.

Current energy prices have cast doubts over the viability of future LNG facilities to the point it is likely that there will be a paradigm shift in criteria used to structure new projects. Potentially these will become smaller and more capex driven, possibly with phased project development to mitigate financial risk. Innovative design and project execution strategies will also be required to meet the challenging investment return hurdles of the current era. Given buyers' procurement leverage in an over-supplied market, LNG suppliers will also have to cope with shorter duration and more flexible off-take contracts and wider use of the spot market.

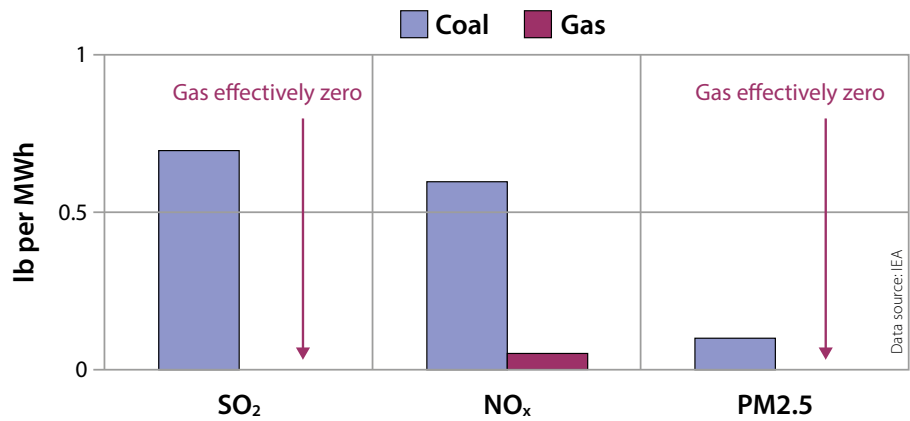

Relative emissions of environmental pollutants other than CO<sub>2</sub> for best-in-class coal and gas-fired power plants (Supercritical boiler vs. CCGT).

### Traditional Technologies

Recent base load LNG schemes have deployed large trains (typically multiple 5 MMt/y), built onshore, with multi-refrigerant liquefaction systems. The dominant technology suppliers have been Air Products, Shell and ConocoPhillips, all using liquid hydrocarbon refrigerants, typically extracted from the feed gas, which requires additional plant and equipment beyond the refrigeration and liquefaction plant itself. A further factor impacting the traditional base load designs is that they need very large gas fields to provide an adequate reserve life to recover the high capital costs. As an example, a 2 x 5 MMt/y train LNG plant would exhaust a 5 Tcf reserve in only ten years. This, together with the capital cost and pricing pressures, is a driver to finding a solution suited to lower capacity plants and the more than 1,000 gas fields with reserves in the range 0.3–5.0 Tcf. These smaller reserves in themselves are not

financially trivial: a 1 Tcf field brought to market, even at today's depressed energy prices, is worth \$7.5 billion.

Smaller scale industrial liquefaction technologies have been suggested for the new era. A simpler variant of the base load multi-refrigerant processes, the single mixed refrigerant (SMR) process, has been proposed. However, this technology is less efficient than the multi-refrigerant processes and like multi-refrigerants also suffers a safety drawback for the emerging FLNG market, because some operators consider liquid hydrocarbon refrigerants unsuitable for FLNG with its limited personnel exit opportunities in the event of a fire or explosion.

Nitrogen expander processes have also been proposed for the smaller scale market. Although proven and safer than SMR they suffer from very poor efficiency and require at least 40% more power than base load facilities. Nitrogen schemes have thus traditionally only been deployed at the

Global LNG sales (MMt/y).

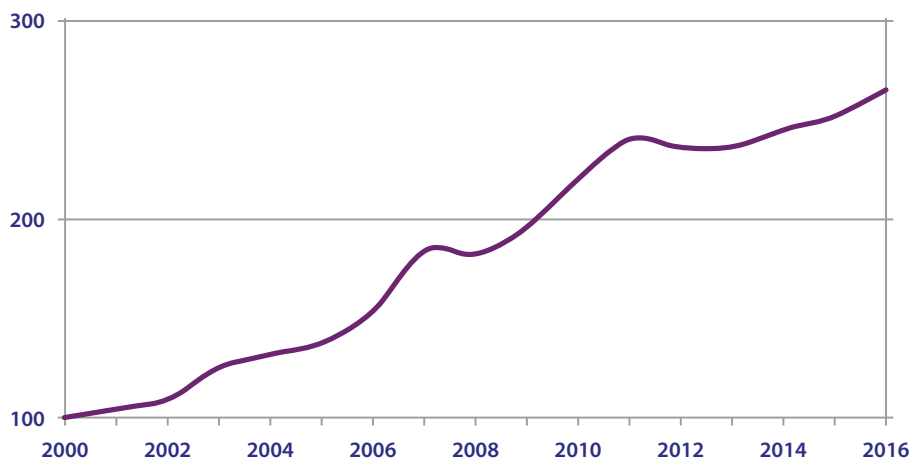



*The LNG carrier Energy Advance in Ishikari Bay, Japan.*

lower capacity end of the market.

### Technology for the Future

FLNG is being widely considered as a solution to cost pressures in the industry. Petronas commissioned its first such facility in early 2017. FLNG eliminates the need for a pipeline to shore for offshore fields. It also reduces some of the regulatory hurdles associated with plants constructed on land. Further, modularized construction and assembly at the shipyard where the hull is built allows fabrication under higher levels of productivity and quality control than prevail at remote locations, saving substantial cost. An additional benefit is that after exhausting one remote field an FLNG facility can be moved to another stranded gas opportunity, producing further revenues.

FLNG schemes will by nature be lower capacity than current base load plants as they are deck space constrained. Multi-train plants with total capacities up to 4 MMt/y are envisaged. Special design considerations will apply – there is a need for compact layouts, lower weight and smaller footprint to minimize the size and cost of the host hull.

New liquefaction cycles also have

a role to play in addressing current cost pressures. An alternative to the use of nitrogen or mixed hydrocarbon refrigerants is to use the feed natural gas as the refrigerant medium. The use of natural gas refrigerant is an excellent fit with FLNG and a number of companies, including Air Products, the market leader in liquefaction technology, have now developed methane cycle schemes.

### Low Cost Process

Gasconsult Limited first developed its liquefaction technology in the mid 2000s when oil prices ranged from \$30–50 per barrel, a challenging scenario comparable to today's circumstances. The objective was to develop a simple low cost process suitable for mid-scale FLNG application. This resulted in the patented ZR-LNG methane cycle process, which uses the natural gas feed as the refrigerant medium in an optimized system of expanders. Compared to mixed refrigerant cycles this eliminates refrigerant storage and transfer systems and the process equipment used to extract refrigerant components from the feed gas.

Refrigeration is effected in two expander circuits (see top right).

The expanders are configured as companders and operate in series with the recycle gas compressor, recovering approximately 35% of the power required to run the system.

ZR-LNG is similar in concept to nitrogen schemes, but it enjoys a fundamental advantage as methane has a higher specific heat than nitrogen. This significantly reduces circulating flows, which in turn reduces power consumption and pipe sizes.

A patented and innovative feature of ZR-LNG is that a partial liquefaction takes place in the low temperature expander CX2 – this very efficiently converts latent heat directly into mechanical energy and also permits a reduction in heat transfer area and cost of the main heat exchanger HX1. An optional liquid turbine TU1 in the LNG run down line also improves efficiency by providing a significant chilling effect.

These features, together with the optimized distribution of flows, temperatures and pressures in the expander circuits, makes for a highly efficient system, around 280 kWh/tonne of LNG in temperate climates. This is equivalent or better than SMR and 30% lower than dual nitrogen expander schemes. In terms of



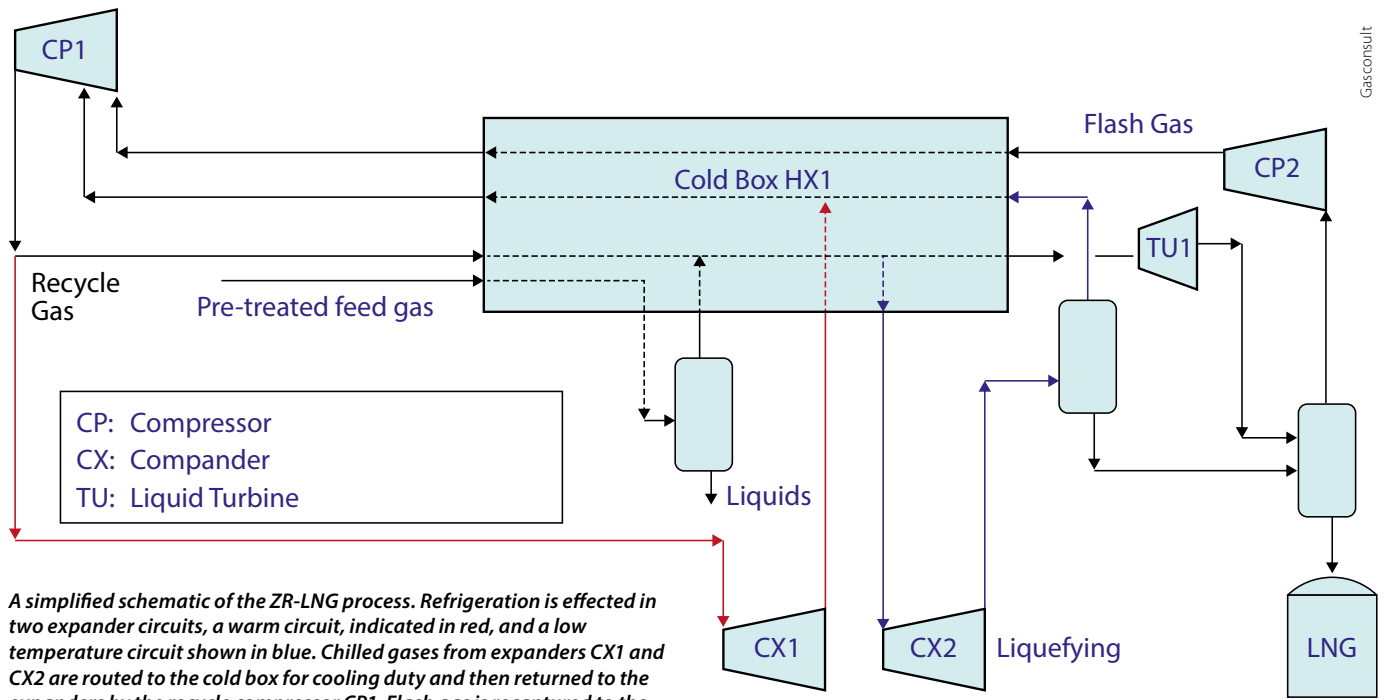

A simplified schematic of the ZR-LNG process. Refrigeration is effected in two expander circuits, a warm circuit, indicated in red, and a low temperature circuit shown in blue. Chilled gases from expanders CX1 and CX2 are routed to the cold box for cooling duty and then returned to the expanders by the recycle compressor CP1. Flash gas is recaptured to the system by a small compressor CP2 and routed through the cold box to the suction of the recycle compressor for return to the expanders.

efficiency ZR-LNG is best in class of the methane cycle schemes and can achieve single train capacities of up to 2 MMT/y of LNG.

**Significant Advantages**

In addition to low power demand and reduced equipment count there are a number of other advantages to the methane cycle concept.

For example, there are no refrigerant logistics issues in remote or offshore locations. Importing hydrocarbons and segregated storage to facilitate blending a mixed refrigerant are not required, and absolute security of refrigerant supply is assured. The process is well suited to lean feed gases as no liquid hydrocarbon feed gas components

are required for the refrigerant, and no propane or other liquid hydrocarbon refrigerants are used – a major safety plus relative to mixed refrigerant schemes, particularly for FLNG as mentioned previously.

Single phase refrigerant makes the system motion tolerant and well suited to FLNG, as does the reduced cost, weight and footprint resulting from the absence of refrigerant extraction equipment and infrastructure. Unused space on the FLNG vessel could be used to install additional productive liquefaction capacity.

Costs are reduced, since the make-up refrigerant is low cost natural gas as opposed to purchased or extracted hydrocarbons or nitrogen, plus there is a shorter start-up time and reduced flaring.

**The Way Ahead**

Gas will play a major role in meeting the challenge of global warming and in providing a more benign atmospheric environment. More gas is needed to achieve this and increasingly this will be supplied as LNG. At today’s challenging energy prices and with the incentive to monetize smaller discovered reserves the LNG industry needs new solutions. FLNG with its ability to process multiple smaller stranded reserves will be part of the equation. Methane expander cycles offer an efficiency very close to traditional base load schemes but with an inherent simplicity that reflects in lower capital costs. They are an excellent fit with FLNG and offer an intrinsically safer operating environment than mixed refrigerant schemes. ■

Power recovery using the ZR-LNG process.

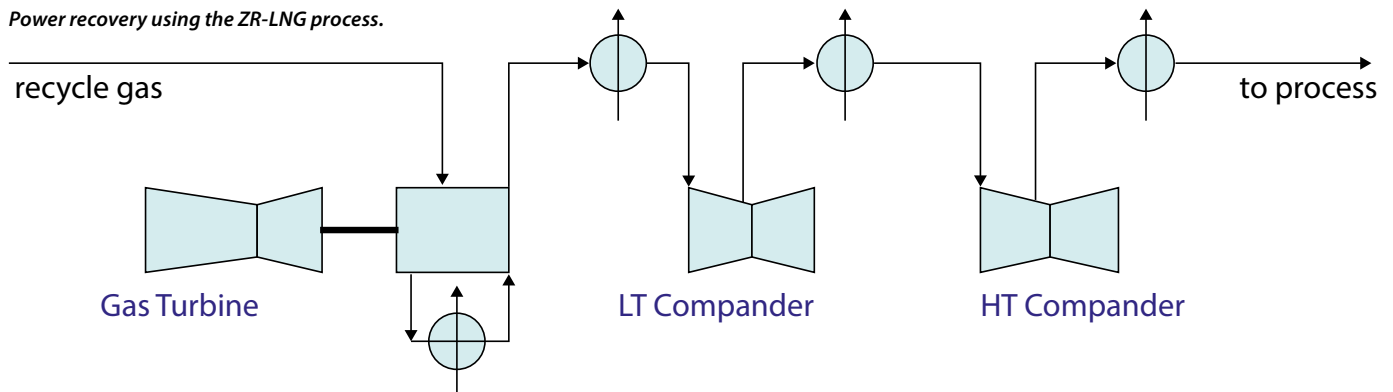

# Deep Offshore Exploration in Greece

Newly processed seismic will uncover hydrocarbon resources hidden offshore Greece.

**YANNIS BASSIAS, Ph.D., President and CEO, Hellenic Hydrocarbon Resources Management SA**

Recent interest in the areas south-west and west of Crete and in the Ionian Sea between Greece and southern Italy have brought western Greece to the attention of the oil and gas exploration industry, spurred on by East Mediterranean discoveries like Zohr in Egypt and Aphrodite in Cyprus. Hellenic Hydrocarbon Resources Management (HHRM), which was established in September 2011, provides today an innovative route to the management of Greek hydrocarbon resources. The company is now studying new tenders for the area, suggesting that, despite the present low oil price, the search for hydrocarbons in Greece is of increasing interest, as new technologies boost the cost-efficiency of operations.

## Expressions of Interest

Despite a couple of bid rounds, there has been very little exploration in Greece since the discovery of the ~40 MMbo (in-place) Katakolon field in the 1980s. HHRM has therefore undertaken to attract international and domestic companies interested in investing in the exploration, development and production of hydrocarbons in Greece, operating as an independent authority to ensure flexibility and avoid heavy bureaucratic procedures. The immediate objectives of the company include the finalization of lease contracts, as well as negotiation and follow-up with the interested companies.

The region of the Ionian Sea and Western Greece in general offers a 'safe haven' in the western part of the Eastern Mediterranean in comparison to trouble hot spots further east. Its strategic location means it is crossed by a number of gas pipelines, including the planned Trans Adriatic Pipeline

## Current acreage in Greece.

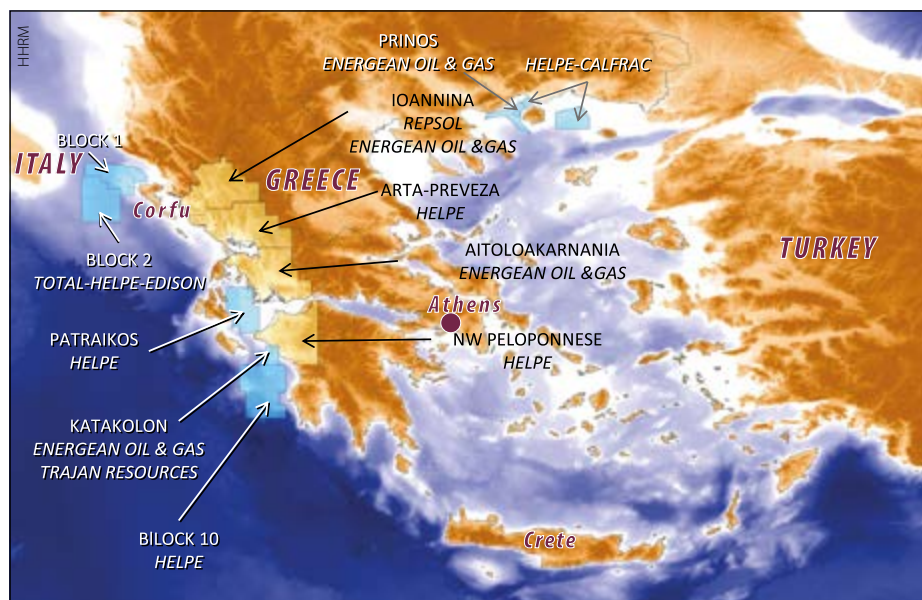

from the Caspian to Europe, so co-operation between neighboring countries such as Greece, Italy and Albania is important. Edison, an Italian subsidiary of French company ERDF, is part of a consortium with Total and Helpe (Hellenic Petroleum) that is already exploring in Block 2, west of the island of Corfu, which it was awarded following the 2014 bid round. Edison holds similar concessions offshore Italy and is looking into continuity across the Adriatic Sea.

The industry has now turned its interest to the unexplored area west and south of Crete, based on interpretation of seismic from the multiclient survey acquired by PGS in association with the Greek government in 2012. This area is considered to be 'high risk, high reward' and has already attracted expressions of interest from a consortium of Total, Exxon and Helpe, which has initiated an international call for tenders for the exploration and exploitation of hydrocarbons offshore west and south-west Crete. Negotiations are also underway with Energean Oil and Gas, which is interested in a new area west of Block 2, which similarly has initiated a call for tenders. Interested companies should submit offers to HHRM within 90 days of the date of publication of the Invitation for Submission of Offers in the Official Newspaper of the European Union.

## New Seismic

HHRM is also overseeing the reprocessing with depth migration of 12,500 kms of the 2012 2D seismic data acquired along the western and southern edges of Greece, which has been underway since July 2017. The pre-stack time migration of

the fast track priority lines from south of Crete will be available in September 2017 and the pre-stack depth migration versions will be released in January 2018, with reprocessing completed by June 2018. Advances in wavefield separation and new de-multiple processes together with depth migration are expected to bring significant enhancements to the data.

The acquisition of new seismic in selected areas is being considered by HHRM, including a 3D survey of up to 2,000 km<sup>2</sup> on the eastern slope of the carbonate platform in the northern Ionian Sea, to the west and south of Corfu. Reprocessing of the new 2D lines will increase the geological understanding of the area and assist in planning the 3D survey.



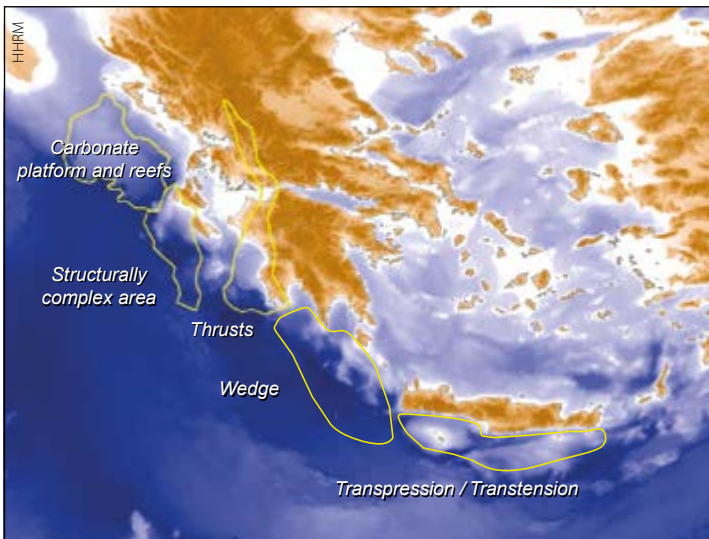

Geological environments with petroleum interest, west and south of Greece.

In addition, HHRM is proposing the acquisition of an infill 2D survey south of Crete with optimized line orientation and an infill 2D acquisition south of the Peloponnese; in total, up to 4,000 km will be acquired. Both surveys are subject to industry prefunding.

### Future Bidding Round

In 2014 a bid round for blocks offshore Crete attracted no offers. Interest in the region has been growing so fast, however, that now, in mid-2017, the area held by the industry or under negotiation represents around 61% of the size of the total acreage offered in 2014, compared to 5% of that same area at the end of 2016. More acreage is expected to become available soon as companies awarded offshore blocks in the last round will have to relinquish 25% of their acreage, which, coupled with the information from the reprocessed data, may lead to a new bidding round by about 2020.

There remain, however, some very basic questions about the geopolitical balance and policy that Greece should follow, bearing in mind its position at the crossroads of energy routes from the Eastern Mediterranean to Europe. The potential for finding important reserves of hydrocarbons in Greece has been a matter of national political debate for some years. While some argue that large discoveries will lead to 'El Dorado', others remain cautious. HHRM therefore hopes to bring together the right technical, legal and financial resources in order to help improve the institutional framework for hydrocarbons with the aid of skilled experts and experienced scientists and professionals. ■

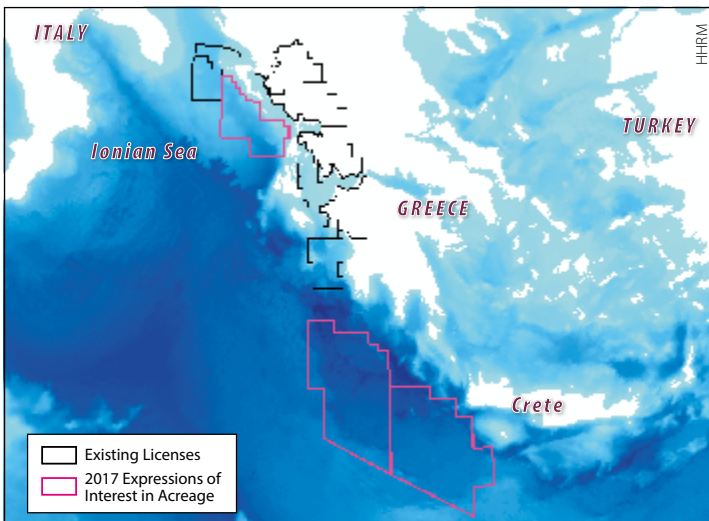

In mid-2017 the acreage held by the industry or under negotiation, including the recent 'expressions of interest' areas, represents around 61% of the size of the total acreage offered in 2014.



Ocean Bottom Seismic

## MASS Marine Autonomous Seismic System



### Modular & mobile system for ROV deployment

Additional applications:

- Large scale cable deployment
- Reservoir monitoring
- Ultra deep water deployment

Our MASS node is the most compact and light weight 4C node sensor in the seismic industry.

- Miniaturised Technology
- Depth Range 0 - 3000 meters
- 32 bit ADC Resolution
- Chip scale Atomic clock
- 64 - 128 Gbyte Internal Flash Memory
- Dynamic Range 127 dB @ 2ms Sample Rate
- Fully Programmable CU
- Up to 150 days recording time

Combined with fully automated handling system - we are proud to say we are delivering Next Generation Ocean Bottom Seismic acquisition services.

[www.magseis.com](http://www.magseis.com)

# Oil Prices and Crises

## A Brief History of Booms and Busts: Part I

Most of us know about the oil shocks of 1973 and 1979 and the market crashes of 1985 and 2014 (which still continues). OPEC is often blamed for such crises but ever since its emergence in the mid-19th century the oil industry has witnessed periods of relative stability sandwiched by episodes of rapid price rises and falls. Although supply and demand has been a major factor in these oil crises, the causes and consequences of each episode have varied. In this two-part article we first review the history of price fluctuations in the modern oil industry from 1859 to 1959.

RASOUL SORKHABI, Ph.D.

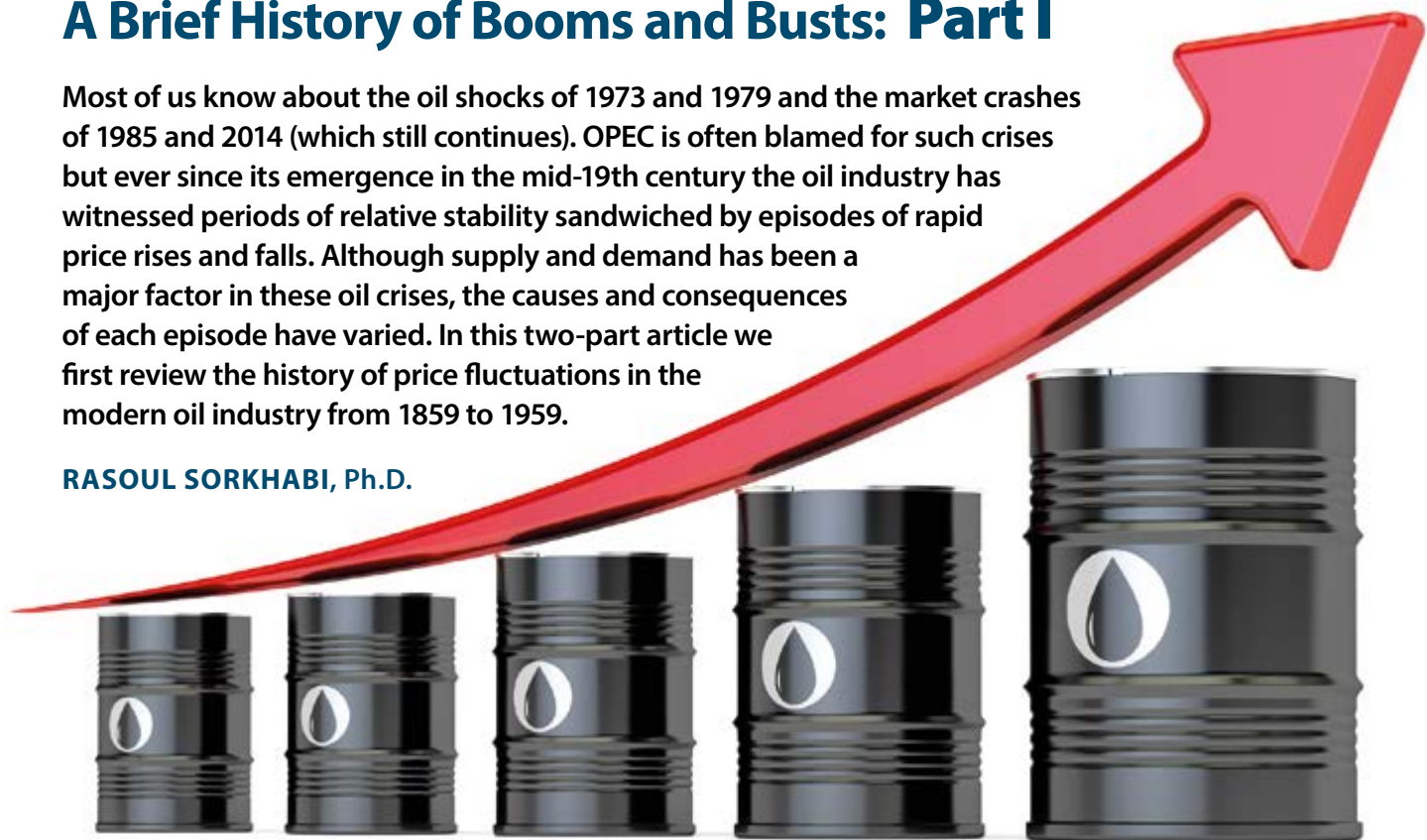

Oil booms and oil busts are both 'crises' that disrupt market stability and create confusion in economic, political and industrial circles. And because oil is a basic commodity linked to nearly all of our activities, oil market volatility is quickly transferred to other sectors of

society as well. What is considered an 'oil boom' for the industry is actually an 'oil shock' for consumers. High oil prices, if maintained too long, encourage a shifting away from oil, thus hurting the oil industry; on the other hand, drastic falls in prices, although temporarily advantageous for consumers, are 'market crashes' for the industry, limiting its capability to invest in new exploration and to meet the rising oil demand (rising partly because of low oil prices). Oil market stability, therefore, provides an optimum functionality for investors, producers, planners, governments, and consumers.

Predicting oil prices and crises is a great game in today's economy and geopolitics, but everyone agrees that it

is a hard game too. Perhaps the history of oil booms and busts offers a realistic perspective on the forces determining oil prices and crises.

### The Pennsylvania Years: 1859–1867

The modern oil industry began in 1859 in Pennsylvania, or so the story goes. In this simplified narrative, Edwin Drake drilled a well close to an oil seep in Titusville to extract oil; his persistence and hard work paid off, and that discovery well ushered in the new hydrocarbon age (see *GEO ExPro* Vol. 6, No. 3). But why did Drake decide to drill an oil well? The answer is the old adage "necessity is the mother of invention". In other words, technological advances are rooted in market demands. This was, is and will be true for oil everywhere.

In 1853, when Robert Edwin Dietz in New York began producing kerosene lamps, he created a huge market for





oil. Drake's drill was in response to that demand. Therefore, right from its beginning, the oil industry was closely related to the availability of markets. That is why, in 1859 as soon as oil came out of wells, it was sold, on average, at \$16 a barrel – equivalent to \$442 a barrel at today's price! This created a craze for oil drilling; production increased from 2,000 barrels in 1859 to 0.5 MMbo in 1860 and 2 MMbo in 1861. As a result, supply far exceeded demand and the price dropped to merely \$0.49 (= \$13) in 1861. Indeed, the oil market crash of 1861 was so severe that oil producers in Pennsylvania founded the Oil Creek Association to limit oil production. Within the first two years of its birth, the oil industry had experienced its first boom and its first bust. Hence the law of supply and demand set the pattern for oil prices.

Cheap prices motivated huge consumption of oil. The American Civil War of 1862–1864 further increased oil prices as the war cut parts of the supply, showing the importance of oil for war and life, and the impact of supply cuts on oil prices. At the end of the Civil War oil was traded at about \$10 (= \$146) a barrel. During 1864–65, oil enjoyed a boom, partly because of hyper-inflation as both North and South printed huge amounts of money to finance the war. A new factor – inflation or, in other words, how much money is worth – was superimposed on the law of supply and demand, and is still valid; when the US dollar, in which oil is traded, is weak in the international market, oil prices go up. The 1865 boom did not last long, and within two years oil prices were back to \$2.40 (= \$41) because of overproduction; another cycle of boom and bust, within a fairly short period of time.

### Enter Rockefeller: 1870s–1900s

By 1867, within a decade of the start of the industry in North America, almost all the key factors influencing oil prices had been recognized and tested; these were later incorporated into the global economy and geopolitics. In the 1860s, even though the US exported oil to Europe, oil was not a major product on the global market. Therefore, the oil booms and busts of this early era

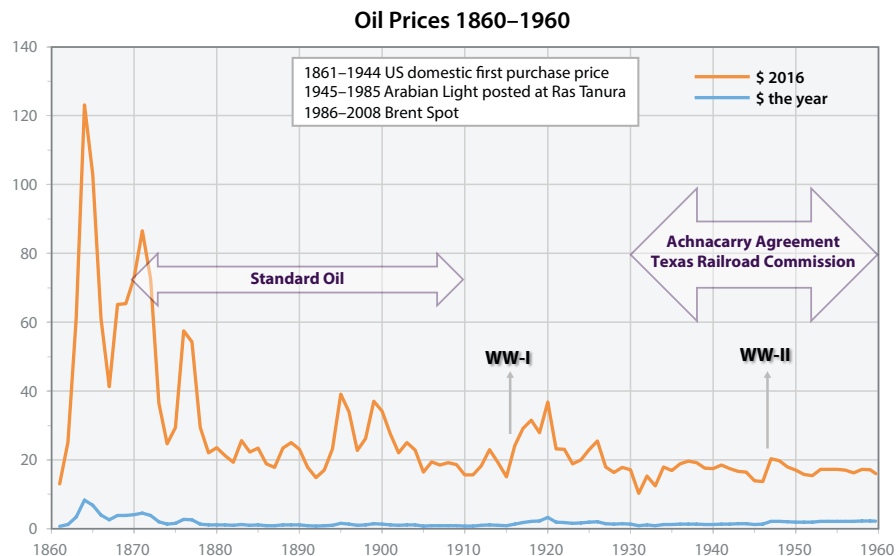

**Chronology of oil prices 1860–1960 (source: BP Statistical Review of World Energy 2017).**

affected economies locally rather than globally. However, local economy was important to local people, particularly to a businessman as shrewd as John D. Rockefeller. He had made a fortune during the American Civil War and had founded a refinery in 1863 in Cleveland, Ohio, which became the nucleus of Standard Oil of Ohio in 1870, followed by the Standard Oil Trust in 1882. During the 1870s–1880s, Rockefeller's company dominated American oil business, partly through forcing out his rivals by sometimes unethical practices. Eventually Standard Oil was split into 33 separate companies by the order of the US Supreme Court in 1911. (For more on J. D. Rockefeller and the rise and fall of Standard Oil, see *GEO ExPro*, Vol. 8, Nos. 2, 3 & 4.)

Despite many criticisms of Rockefeller and Standard Oil, they brought some stability and lower prices (compared to the 1860s) to the North American oil market as they reduced the mushrooming number of oil producers and refiners in the region. Nevertheless, the period 1870–1900 had its own bumps too, with a boom when oil prices rose

to \$4.34 (= \$82.30) in 1871 followed by a bust in 1874 (\$1.17 = \$23.60). In 1876 they rose to \$2.56 (= \$55.10) mainly because Jon Strong Newberry, Ohio's Chief Geologist, declared that the US was running out of oil – the first 'peak oil' prediction. This boom was short-lived and oil prices fell back to \$0.86

*John D. Rockefeller (1839–1937), co-founder of the Standard Oil Company in 1870. His company controlled over 90% of US refineries. Standard Oil is the mother of Exxon, Mobil, Marathon, Chevron, and many other American oil companies.*



## History of Oil



A 1910 Model T Ford car, photographed for an advert by Harry Shipler in Salt Lake City.

(\$19.20) in 1881. Indeed, from the 1870s up to World War I, oil prices remained less than \$1 a barrel except for two brief periods.

During the 1880s–1890s, two factors, other than Standard Oil, contributed to lower oil prices. First, Edison's invention of electric bulbs in 1885 diminished the prospect of kerosene lamps as a major source of illumination, while wood, rather than natural gas, remained the main source of heating. Secondly, as oil production and trading became an international enterprise, the first 'oil wars' were launched among

the oil traders, including Standard Oil, Czarist Russia (represented by the French Rothschild family and the Swedish Nobel family), Royal Dutch Petroleum of the Netherlands, and the Shell Company of the British Samuel brothers.

By the 1900s, new trends were in place. Henry Ford began manufacturing convenient models of gasoline-powered automobiles which, over the years, became popular. In 1907, the first drive-in gasoline station opened in St. Louis. The successful aircraft flight of the Wright Brothers in 1903 ushered

in a new age of aerial warfare and transportation. In 1907 Royal Dutch and Shell merged; the group is still one of the world's oil giants. The naval powers, including Britain's Royal Admiralty in 1911–1912, made the strategic decision to convert their coal-powered fleets to faster oil-powered warships. These trends were the seeds of rising oil prices. New oil discoveries, however, intensified the globalization of the oil industry, while finds in Texas, Oklahoma, Louisiana, Kansas and California during the 1900s extended the American oil industry far and wide beyond its north-eastern corner. The discovery of oil in Iran (Persia) in 1908 put the Middle East on the world's oil map; the following year the Anglo-Persian Oil Company, owned largely by the British government, was formed. In 1910, the Golden Lane oil field in Mexico and Miri in Borneo were discovered.

### World War I and its Aftermath: 1910s–1930s

Lord Curzon, Britain's Secretary of State for Foreign Affairs, famously remarked that in World War I (1914–1918) Great Britain and the Allies "floated to victory on a sea wave of oil". A fifth of Great Britain's oil came from the 'cheap' Persian fields. Indeed, the war established oil as a strategic commodity for the industrial powers and triggered a century of oil colonialism around the world. The world after the war



Achnacarry Castle in north-west Scotland, where representatives of the 'Seven Sisters' met to attempt to regulate oil production and marketing through the Achnacarry Agreement.



Organised By:



# 24<sup>th</sup> Africa Oil Week



## Africa Upstream

### 23<sup>rd</sup> - 27<sup>th</sup> October 2017

Cape Town International Convention Centre, South Africa

24<sup>th</sup> Africa Upstream

17<sup>th</sup> Africa Independents Forum

80<sup>th</sup> PetroAfricanus Dinner in Africa

9<sup>th</sup> Global Women  
Petroleum & Energy Luncheon

5<sup>th</sup> Africa Local Content Forum

5<sup>th</sup> Young Professionals  
Oil, Gas & Energy in Africa

2<sup>nd</sup> Africa Exploration Technology

The leading conference and networking forum  
for exploration strategy and deal-making

[www.africa-oilweek.com](http://www.africa-oilweek.com)

Lead Sponsor



Titanium Sponsor



Rhodium Sponsor



Sponsors



Supporting Sponsors



For more information or to book your seat, contact:

Sonika Greyvenstein  
[sonika.greyvenstein@ite-events.com](mailto:sonika.greyvenstein@ite-events.com)

Amanda Wellbeloved  
[Amanda.Wellbeloved@ite-events.com](mailto:Amanda.Wellbeloved@ite-events.com)

Harry Harrison-Sumter  
[harry.sumter@ite-events.com](mailto:harry.sumter@ite-events.com)

London: +44 207 596 5065  
Johannesburg: +27 11 880 7052

## History of Oil

was different: Russia became the Soviet Union following the Bolshevik Revolution of 1917; the Ottoman Empire, a German ally defeated in the war, spilt into modern Turkey and a number of new Arab nations in the Middle East; and a new oil player, the Turkish (Iraqi) Petroleum Company, began competing with the Anglo-Persian in the Middle East.

World War I pushed oil prices from \$0.81 (= \$19.40) in 1914 to \$3.07 (\$36.80) a barrel in 1920, a direct response to rising oil demand as more cars, ships and air planes were on the move. The US Bureau of Mines and the US Chief Geologist David White expressed concerns about peak production in the country, thus encouraging American oil companies to explore for oil worldwide, which they did, but in 1921 oil prices crashed to \$1.73 (= \$23.20) a barrel.

Indeed, from the 1920s–60s the average annual oil prices were \$2 a barrel or less (averaging \$1.50). This long price stability coincided with the golden age of oil in terms of growth, employment, exploration and discoveries. Oil increasingly replaced coal as a more efficient, high-density energy source. What were the forces behind the long market stability of the 1920s–60s?

For one thing, advances in science and technology, including rotary drilling, seismic surveying, well logging and subsurface geological mapping, made oil exploration and discoveries more successful. Moreover, global exploration for oil was strategically supported by the American, British, French and other Western governments. Major Western oil companies were members of oil consortia in the Middle East, South East Asia and Latin America. Enrico Mattei, who desired his Italian company to be part of this international oil club, called them the ‘Sette Sorrelle’ – the Seven Sisters: British Petroleum, Royal Dutch Shell, Exxon, Mobil, Texaco, Chevron, and Gulf Oil. (He had left out the French oil company in order to demonize the Anglo-American companies.)

The Seven (or eight) Sisters had in their hands 80% of the world’s oil reserves outside the USA, and they coordinated to regulate production and minimize downstream competition. This

started in 1928 when Sir John Cadman of BP invited the managers of the Seven Sisters to Achnacarry Castle in Scotland for a weekend negotiation to prevent disorder in their global oil business. The secret Achnacarry Agreement was exposed in 1952 by John Blair (who later wrote *The Control of Oil*).

Oil market stability was also regulated in the US. Indeed, oil exploration and production between the two world wars had proved to be too successful, and the real challenge was maintaining a balance between supply and demand even by force. In his recent book, *Crude Volatility*, Robert McNally recounts how state governments imposed military law on two oil fields (in Oklahoma and East Texas) in 1931 and sent armed troops to shut down the producing wells and thus reduce overproduction or so-called ‘physical waste’!

Overproduction coupled with the Great Depression were major factors in low oil prices in the early 1930s. In 1932 US President Hoover set a tariff of \$0.21 per barrel on imported crude (about 23% of the domestic crude price). Eventually, the Texas Railroad Commission took over the task of regulating oil production in Texas and neighboring states to prevent lower oil prices – a task which they strictly performed from 1935 through the 1960s.

*Texas Railroad Commission founded in 1891 is headquartered in the William B. Travis State Office Building in Austin. It regulated US oil production (and hence prices), and became an inspiration for today’s OPEC.*



## World War II and its Aftermath: 1940s–1950s

Although the period 1920s–60s experienced a relatively stable oil market, it did have several episodes of price fluctuation. World War II (1939–45) increased demand for warfare oil. After the war oil consumption increased even more drastically because of the reconstruction of Europe, improved life standards, and population growth. Nevertheless, major Western oil companies with the blessings of their governments were able to increase their reserves and production as needed. The Suez Canal crisis of 1956–57 was the first post-war political oil shock; but the price increases were short lived.

In the mid-1950s, with the coming of Russian oil to the global market, oil prices fell. The independent oil producers in the US were alarmed that the import of cheap foreign oil by major American companies to the US could have destroyed their businesses. Under pressure from these companies, President Eisenhower created the Mandatory Oil Import Quota Program in 1959, according to which US import of foreign crude oil could not exceed 12% of domestic production. The import quota was lifted by President Richard Nixon in 1973 when the US needed to import huge amounts of oil – further instances of government intervention in stabilizing the US oil market. ■



# STRIKE WHILE THE DEALS ARE HOT

## NAPE IS THE MARKETPLACE FOR THE BUYING, SELLING AND TRADING OF OIL AND GAS PROSPECTS

**NAPE SUMMIT**  
FEB 5 – 9, 2018 | HOUSTON

**SUMMER NAPE**  
AUG 15 - 16, 2018 | HOUSTON

WE CAN'T TELL YOU WHAT  
**YOUR NEXT DEAL** WILL BE.  
BUT WE CAN TELL YOU  
**WHERE IT WILL HAPPEN.**

**NAPE**  
*Where Deals Happen*

Success in any field depends on a combination of what you know and who you know. In the upstream oil and gas business, NAPE is your [international](#) gateway for getting connected with the decision makers who can make things happen. If you're looking for the connections that will open a thousand doors, come to NAPE - where deals happen.

LEARN MORE AT [WWW.NAPEEXPO.COM](http://WWW.NAPEEXPO.COM)



# Unlocking the Mysteries of the THOMAS SMITH Great Sand Dunes

While the story behind the formation of the Great Sand Dunes is still being unraveled, the visitor to this part of Colorado will be enveloped by a geologic wonder and a truly spectacular sight.

The Great Sand Dunes occupy a small portion of the eastern edge of the San Luis Valley, the largest intermontane basin in the southern Rocky Mountains. The current valley is part of the Rio Grande rift that extends more than 1,000 km from northern Mexico to these mountains. The San Luis Valley portion of the rift is 220 km long and 75 km wide. It is closed off in the north by the convergence of the Sangre de Cristo Range with the San Juan Mountains to the west, and in the south by the same Sangre de Cristo Range meeting the Tusas Mountains.

Visitors to the Great Sand Dunes National Park have access to desert dunes, dry lake beds, and small streams that disappear into the valley. Above the valley, one encounters pinyon pine and aspen groves in the foothills, spruce and fir forests higher up on the mountain slopes, finally culminating in high alpine tundra and the rocks of the area's two tallest peaks, Crestone Peak (4,357m) in the north and Blanca Peak (4,372m) in the south.

## Unraveling the Story

"The age of the Great Sand Dunes has been debated for nearly 150 years," according to Dr. Richard Madole, geologist and scientist emeritus, US Geological Survey. "The northern San Luis Valley is covered by Quaternary

*Rising above the San Luis Valley, North America's tallest sand dunes are dwarfed by the 4,000m peaks of the Sangre de Cristo Mountains.*

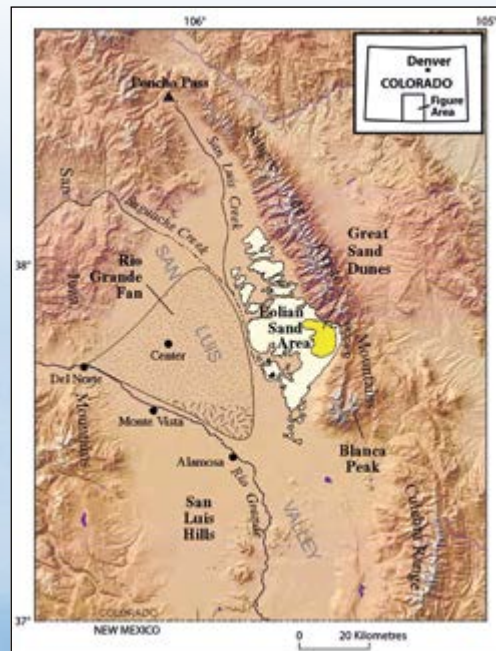

Location map for Great Sand Dunes National Park and Preserve (dune area shown in yellow). Madole, USGS





deposits and penetrated by hundreds of water wells. These deposits have never previously been differentiated or mapped in any detail. This lack of information has led to seven ages for the dunes, ranging from Miocene to late Holocene, as well as three principal hypotheses for their formation.”

For the past decade, Dr. Madole’s research has been focused on the history of water table fluctuations near Great Sand Dunes National Park, as well as the surficial geology and geomorphology of the Great Sand Dunes area. A recent paper on the subject, published in 2013 with co-authors Mahan, Romig, and Havens, uses detailed mapping, stratigraphy, and new age dating to help solve the mystery of the age and origin of North America’s highest dunes. In 2016, Dr. Madole and others published the *Geologic Map of Great Sand Dunes National Park, Colorado*, which contained further details from their excellent field studies.

“Our findings published in these two papers involved a variety of Quaternary studies and methods aimed at making the first surficial geologic map of the Park,” says Dr. Madole.



Thomas Smith

*Established in 2004, Great Sand Dunes National Park and Preserve is tucked up against the Sangre de Cristo Mountains in south-central Colorado. The enormous scale of this dune field becomes apparent as you approach on foot. Rising to over 230m and covering 72 km<sup>2</sup>, “Their appearance was exactly that of a sea in a storm (except as to the color)”, as western explorer Zebulon Pike described them in 1807.*

“We used LiDAR, Landsat (satellite) imagery and aerial photography, as well as subsurface stratigraphy from logs of several hundred wells ranging from a few meters to 120m in depth. To characterize, correlate and date the surficial deposits, laboratory analyses were conducted, including particle-size analyses, X-ray powder diffraction (XRD) of minerals, trace elements

and heavy mineral analyses, fossil identification (ostracod and diatom), radiocarbon, and optically stimulated luminescence (OSL) ages.

“Using the new information, primarily the subsurface stratigraphic data, OSL dates, and geomorphic evidence,” says Dr. Madole, “we have been able to narrow the range of dates over which the Great Sand Dunes formed.”





### The Age of the Dunes

Two things are necessary for a dune field like the Great Sand Dunes to form – an abundant source of dry, sand-sized grains, and a smooth surface free of non-erodible elements such as vegetation and rocks. It then requires some wind to move the sand to a location where it can accumulate.

Research by Dr. Madole and others has revealed that the nearby source of sand (see section below, Material Source and Dune Formation) for the dunes was the floor of the closed basin that occupies the northern portion of the San Luis Valley. Before the Pleistocene glacial periods, the Rio Grande and other streams entering this valley delivered miniscule sediment loads when compared to those received during glacial periods. It took the high fluvial energy generated during glacial times to deliver the large volumes of sand across the San Luis Valley needed to form the dunes. This conclusion alone eliminated the suggested older Miocene and Pliocene origins for these great dunes.

Further evidence for eliminating these earlier dates lies in the fact that the formation of Lake Alamosa during the middle Pliocene would have blocked sediment delivery across the valley. This body of water, which episodically covered a large part of the northern San Luis Valley, was formed when the Servilleta Basalt (3.66–4.75 Ma)



*The dune field sits in a bow in the mountain range. Prevailing winds are from the south-west (bottom left) across the valley toward the mountain range. Note how the dune field has deflected streams exiting the mountains.*

dammed the Rio Grande River. The draining of this lake about 440,000 years ago would further help researchers narrow down the timing at which dune formation could commence.

Detailed mapping placed the dunes directly overlying a westward thinning wedge of debris-fan deposits derived from streams exiting to the west out of the Sangre de Cristo Range. This wedge of the piedmont/slope deposits

progrades into the valley and over Lake Alamosa sediments. Since the dunes overlie the proximal portion of this sediment wedge, their formation had to occur after both the deposition of those sediments and the draining of Lake Alamosa, further narrowing the time at which dune formation could begin.

By observing that streams exiting west from the Sangre de Cristo Range have been deflected by the Great Sand

### Exploring the Area

The park is easily accessed from several major highways crossing the valley, and a paved park road connects the highways with the visitor center, campground and parking areas adjacent to the dunes. From the dunes parking area, visitors can cross Medano Creek and hike to the top of the highest dunes. This can be quite an adventure as there are no trails but as one climbs higher into the dune fields, the spectacular mountains come into view across this ocean of sand.

Access to the dunes is a short walk from the numerous parking areas. The park offers a wide variety of recreational opportunities, including hiking, with pets permitted on leash (most national parks do not allow pets outside parking areas), camping, fishing, sledding and sandboarding, as well as simply

enjoying the scenery and exploring the many ecosystems that range from high desert to alpine tundra.







Once up on some of the highest dunes, the views across the sand to the mountains are absolutely amazing.

Dunes, Dr. Madole and associates were able to establish a minimum date for the age of the dunes. They observed that the preserved zones of oxidation and weathering profiles associated with the redirected stream deposits near the mountain front were comparable to those of nearby Bull Lake till (next to last glaciation period). This contrasts with the lack of such oxidation observed along stream deposits from the last glaciation (Pinedale). Comparing the thicknesses of oxidation allowed them to date the deflected stream channel deposits to be at least as old as the Bull Lake glaciation, which ended at about 130ka, and thus conclude that the Great Sand Dunes began to form prior to that time and sometime after 440ka. Recently obtained OSL ages of eolian sand along Medano Creek support the 130ka date.

**Material Source and Dune Formation**

Now that the age of the dunes has been narrowed down, the formation of these deposits becomes less problematic. Early hypotheses for dune origin and source for the eolian sand varied extensively. “Our research into the composition and age of material from the Great Sand Dunes indicated that only about 11% of the material found here was derived from the rocks in the Sangre de Cristo

Mountains,” says Dr. Madole. “The vast majority of the material was derived from the San Juan Mountains located over 70 km to the west and we needed to explain how it was transported east across this valley.

“Referring to published water budget figures, nearly 90% of the inflow into

the San Luis Basin comes from the San Juan Mountains, with the Rio Grande River the largest watershed flanking this basin,” Dr. Madole continues. “Past inflows were likely similar. During the latest Pleistocene time, the Rio Grande drainage was highly glaciated and meltwater carried huge volumes of sediments into the San Luis Valley, forming a large alluvial fan. This fan extended far enough east to deflect the San Luis Creek that flowed along the east side of the valley.

“The sandy, distal edge of this fan bounds the west side of an area we refer to as the sump, which is a flat-floored depression 3 to 5 meters deep and 4 to 15 kilometers wide. Eolian deposits do not extend all along the eastern side of the San Luis Valley but are only located directly north-east of the sump. From this, we concluded that when conditions were favorable, sand was transported from the sump area by the prevailing westerly and south-westerly winds to be deposited in front of a major topographic barrier, the Sangre de Cristo Mountains. Over time, they formed the large dunes we see today.”

*Acknowledgements: A very special thank you goes to Dr. Madole for his information and review. ■*

*Along the valley floor adjacent to the dunes are many unique features, from shallow or dry lake beds to these interesting grass rings. Ring muhly, the clonal grass pictured here, starts out as a small clump that increases in diameter over the years as one single individual grass. Once it has reached a diameter of about 30 cm the center dies out, leaving a hollow ring that gradually grows outward. The arid environment is responsible for this circular growth.*



# The Golden Snitch?

## Borehole Gravity for Reservoir Monitoring

JENNIFER HARE, Ph.D., Micro-g LaCoste, and MATTHEW PLACE, Battelle Memorial Institute

**A shiny, one-inch round, miniature gravity meter is providing key bits of information about the distribution of pore fluids for reservoir monitoring. High-resolution borehole gravity measurements are now possible in deep, hot, small diameter wells of nearly all orientations, including horizontal wells.**

Many of the most pressing needs for gravity surveying in the O&G industry are for monitoring very small, time-variable density changes for enhanced oil recovery (EOR), carbon storage and hazard mitigation. High-resolution borehole gravity measurements are now possible in smaller diameter and more highly deviated wells (including horizontal wells) than ever before. Following suit with land gravity surveying, the borehole gravity (BHG) method routinely achieves 5  $\mu\text{Gal}$  or better repeatability – significantly expanding the applications of this old-school survey technique for monitoring applications. The recent modifications provide an opportunity for implementation of the technology on advanced oil and gas operations with cutting-edge results.

Carbon dioxide storage, steam-assisted gravity drainage (SAGD), and other types of EOR operations can benefit from borehole gravity because the method is sensitive to the mass and bulk density changes caused by pore fluid exchanges relatively far from the borehole. In addition, the method works through casing. Time-lapse borehole data can also be combined with time-lapse surface data, where feasible, providing a comprehensive sampling of changes in gravity occurring both near and distal from the source (e.g., Krahenbuhl and Li, 2012).

A major distinction exists between single time-epoch gravity surveys, where the goal is to recover absolute earth densities and density distributions, and time-lapse (or 4D) gravity surveys where we wish to recover density changes over time. While the local gravity field is caused by the overall geologic structure and characteristics for a considerable distance around a well, the *difference* signal between consecutive, time-lapse gravity surveys is only related to the changes in the fluid density distribution within the pore space between logging epochs. Time-lapse surveying allows us to detect rock fluid changes that are 100 to 1,000 times smaller than the normal background gravity variations that dominate single-epoch surveys.

### It's All About Delta Density

The basic premise of gravity surveying is that gravity measurements are sensitive to mass and density distributions in the earth. For time-lapse gravity surveys, it is the *change* in bulk formation density that is detected: this is due primarily to pore fluids changing saturation and/or replacing or mixing with other fluids.

As an example, consider carbon dioxide ( $\text{CO}_2$ ). The density of  $\text{CO}_2$  varies greatly from the near-surface, where it is a low density gas, to depths greater than about 1 km, where it is a super-critical fluid with a density of about 0.6  $\text{g}/\text{cm}^3$  or greater.



*The latest generation borehole gravity sensors are smaller than a golf ball and operate in cased and uncased wells less than 3 inches in diameter.*

In some scenarios, such as carbon dioxide invasion into shallow/near-surface aquifers, we expect increasingly negative gravity and bulk density anomalies over time, as low density  $\text{CO}_2$  replaces higher density in-situ water.

Another example where we expect increasingly negative gravity anomalies is steam injection into shallow reservoirs. In this scenario, the delta density is also increasingly negative over time. Figure 1a shows a density model of a SAGD reservoir simulation showing steam chambers developing along a group of linear-trending, horizontal injection wells. Borehole gravity combined with surface gravity in this case provides an excellent, 3D spatial sampling of the gravity field from which steam chamber development can be monitored. The forward-modeled borehole gravity signals for this model are shown in Figure 1b.

In some scenarios, we expect densities to increase over time as net mass is added to the reservoir. The borehole gravity method was tested in a late-stage, pinnacle reef reservoir (Dover 33) at about 5,400 ft (1,650m) depth (Cumming, et al., 2017). The survey goal was to assess the capability of the technology for monitoring carbon dioxide movement and storage within a closed reef structure (Figure 2). Two BHG surveys were performed in the  $\text{CO}_2$  injection well to generate time-lapse data: a baseline survey was performed in 2013 while the reef was in a depleted, low-pressure condition (600 psi), and a repeat survey was conducted in 2016 after injection of 265,000 metric tons of  $\text{CO}_2$  into the reef and pressures had increased to 3,500 psi.



In the deep reservoir zone, the gravity difference between the year 2013 and year 2016 surveys in the Dover 33 well clearly showed a broad, approximately 90  $\mu\text{Gal}$ , positive, time-lapse anomaly above the Niagaran Brown (NB) formation that decreased downward through the reef (Figure 3). The largest BHG density change was in the upper 40 ft (12m) of the Niagaran Brown, where a BHG density change of about  $0.04 \pm 0.01 \text{ g/cm}^3$  was indicated. The survey results showed that dense-phase carbon dioxide liquid had filled the pore space previously occupied by low-density natural gas and had increased the density in a portion of the reef where porosity was generally greatest. The data also showed that the injected carbon dioxide had been contained within the reef.

Another time-lapse survey is currently underway in a carbon capture and storage project in Illinois, USA, where captured  $\text{CO}_2$  will be stored in a deep, sealed, saline aquifer. The first borehole gravity survey, completed in early 2017, served as the baseline – the results are shown in Figure 4 on the next page. Note that the BHG densities are somewhat smoother and slightly higher, in general, than the RHOZ (*gamma-gamma* log-based density estimates). This is because BHG is a deep-sensing, density logging method and is not subject to low-density biases due to washouts and other formation disruptions near the wellbore. Examination of the Caliper and Standoff RHOZ correction logs, in this case, showed significant kicks in areas where the RHOZ and BHG densities differed the most.

### The Method Explained

Modern gravimeters measure changes in gravity with  $\mu\text{Gal}$  precision, or about 1 part per billion of gravity ( $g$ ) ( $\sim 10^{-8} \text{ m/s}^2$ ). The latest generation of borehole tools are relative gravity meters using miniaturized, highly specialized spring sensors housed in an approximately 2½-inch diameter tool. Developed in the 2000s, the new borehole gravity meters incorporate key improvements related to accuracy, reliability, calibration,

orientation, tool diameter and positioning over older generation BHG tools that were developed by LaCoste and Romberg in the 1970s (Nind, et al., 2007).

BHG measurements are made at discrete depth intervals, or ‘stations’ in a borehole. Gravity ( $\Delta g$ ) and depth ( $\Delta z$ ) differences between successive stations constitute the interval vertical gradient of gravity which varies directly with the density of the rock layer bracketed by the measurement

**Figure 1b:** Simulated, time-lapse borehole gravity signals in Wells 1, 2 and 3 in Figure 1a.

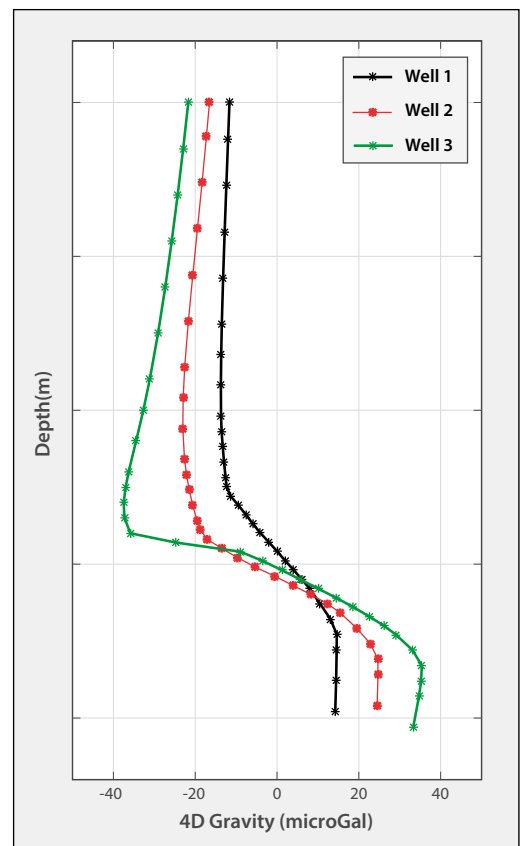

**Figure 1a:** A time-lapse reservoir model for an early-stage, steam injection scenario. The developing steam chambers have a density contrast of about  $-0.3 \text{ g/cm}^3$  with the surrounding reservoir in this model.

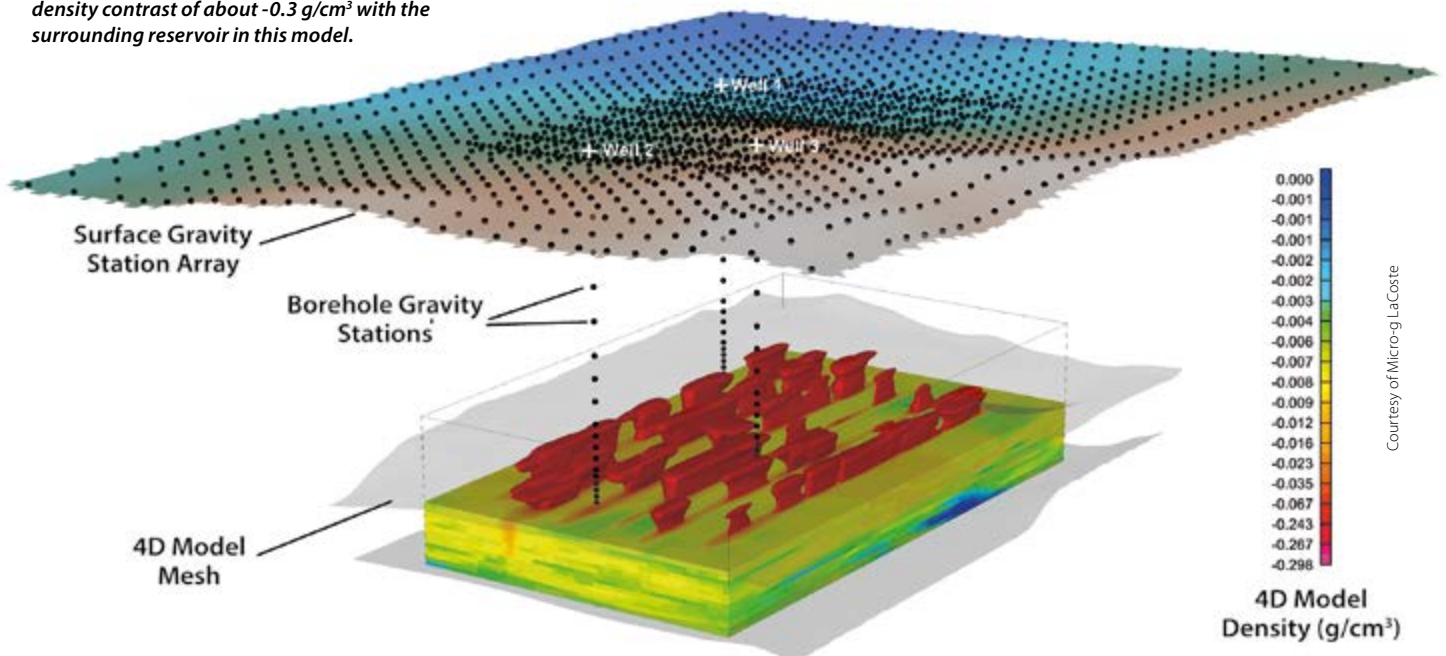

stations. The classical BHG density is the density of an infinite, horizontal slab of thickness,  $\Delta z$ , that is required to produce the difference in the two gravity measurements,  $\Delta g$ . BHG density is an apparent density – an incredibly powerful computed rock parameter, similar to the concept of apparent resistivity, which is computed from electrical and electromagnetic surveys.

Raw BHG measurements are corrected for tides, ocean loading, sensor temperature, tilt, and for small depth differences between station repeats (within a single survey) and sensor drift. Typically, to obtain the highest accuracy, each survey includes three passes through the zone of interest, repeating either a subset or all of the stations. The corrected, observed gravity data are then converted to BHG densities.

For monitoring, the ability to return to the same depth for comparison of gravity changes over time is important. A combination of natural gamma ray and high-resolution casing collar locator tools, which are integral parts of the BHG tool assemblage, provide depth control to 1 cm within cased holes. BHG data can be acquired and tied from the surface to depths of 3 km or more (depending on the ambient well temperature and pressure).

As a general rule, the radial volume of rock sampled

**Figure 2:** Side view of the Dover 33 reef with locations of the deep zone borehole gravity stations. Courtesy of Core Energy, Battelle Memorial Institute and Micro-g LaCoste.

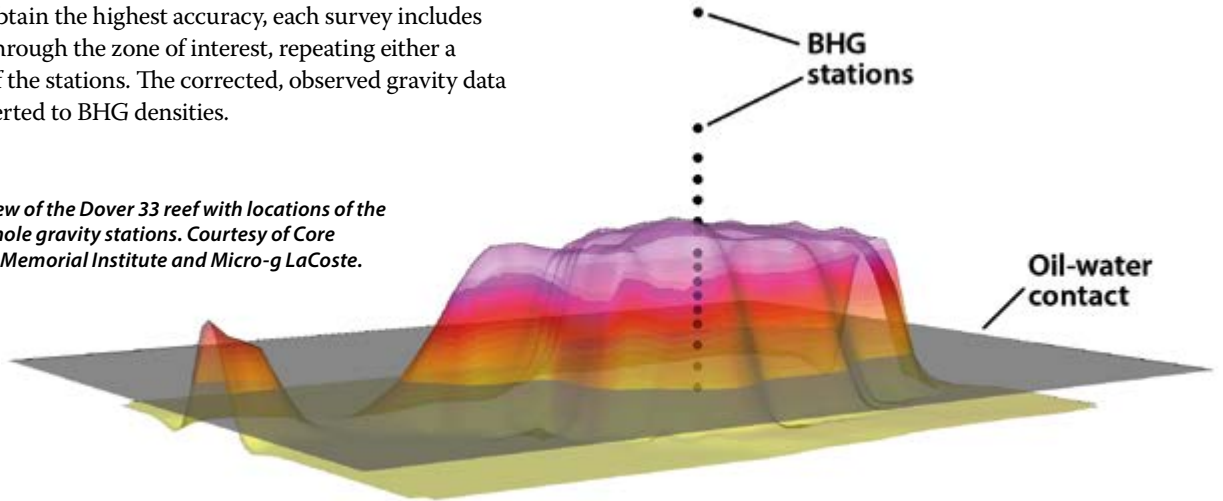

**Figure 3:** Time-lapse borehole gravity survey results in the Dover 33 well. Left: Observed time-lapse gravity difference (2016 –2013). Right: Computed time-lapse BHG densities. OWC= oil water contact; NB= Niagaran Brown (reservoir); A1C= A1 Carbonate (reservoir); A2A= Anhydrite (seal). The well perforations are from 5,309 to 5,460 ft.

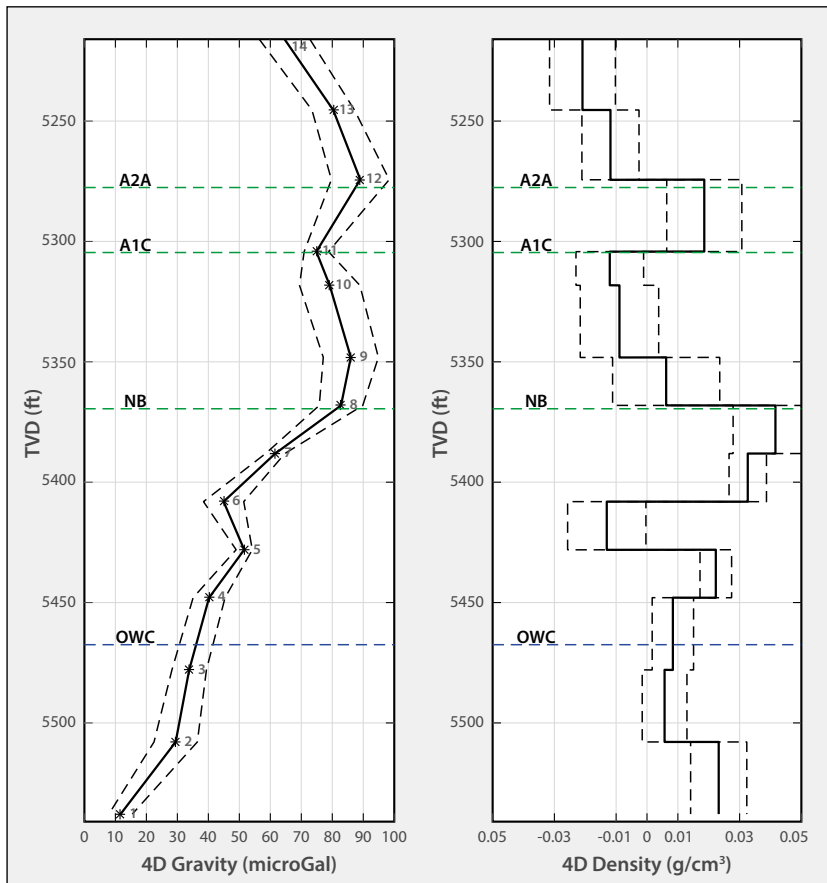

**Figure 4:** BHG densities (blue) and RHOZ densities (pink, red) from a CO<sub>2</sub> storage well in Illinois, USA. Courtesy of Archer Daniels Midland and Micro-g LaCoste.

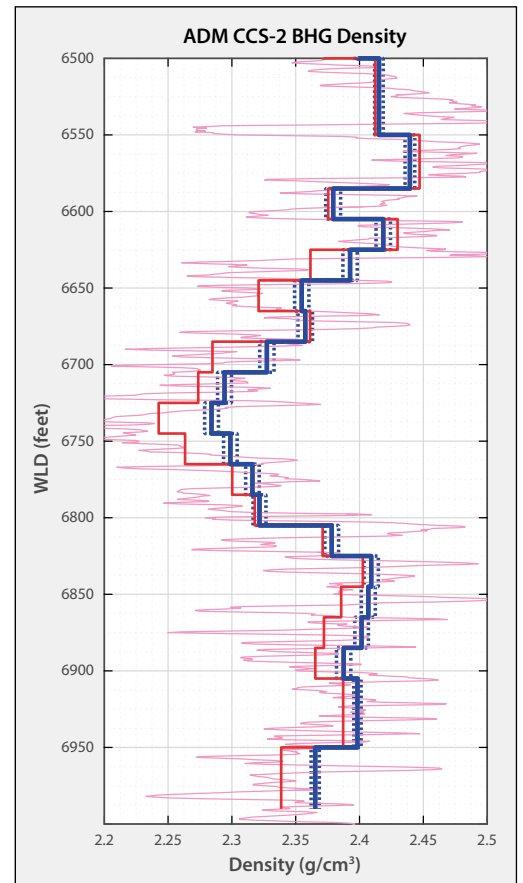



by BHG measurements is about five times the downhole station spacing (in a vertical well). BHG density errors are proportional to gravity measurement errors and *inversely* proportional to the vertical station spacing. Assuming 3.5  $\mu\text{Gal}$  measurement error, we can estimate BHG density for a single survey epoch to 0.003 to 0.007  $\text{g}/\text{cm}^3$ , given typical reservoir monitoring station intervals of 6 or 3m, respectively. For highly deviated wells, BHG densities are best estimated by inversion methods that utilize the full set of every station combination (MacQueen, 2007).

### The Real Magic – Better Results in a Smaller Package

It has long been recognized that the borehole gravity method can provide key information critical to the successful characterization of reservoirs and to the successful monitoring of reservoir dynamics (e.g., Rasmussen, 1975; Popta et al., 1990; Hare and Black, 2015). However, the practical application of the method to monitoring has been severely limited by the older generation, large-diameter tools that could only operate in vertical wells. Recent improvements in the technology are finally propelling borehole gravity monitoring into the realm of common practice.

References available online. ■

### Survey crew assembling the borehole gravity tool.

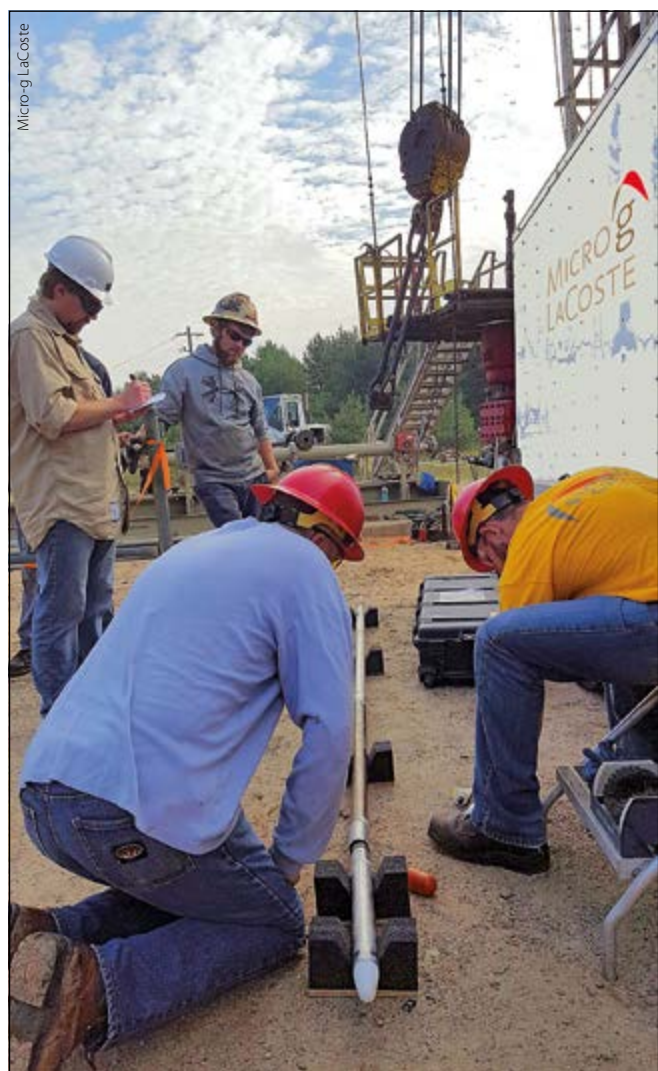

## REDUCE COSTS.

## INCREASE EFFICIENCY AND PRODUCTIVITY.

## REDUCE DATA FRICTION.



In this downturn, reducing costs is paramount. Adopting Energestics data exchange standards is a powerful way to drive cost savings for your company.

When you can find the data you need, know it is from a trusted source and in a format immediately available to an application, you become more productive and efficient and you reduce your costs.

For more information on the benefits of adopting Energestics standards, visit [www.energestics.org/adoption](http://www.energestics.org/adoption)



# Hubbert:

## A Life-Long Quest for the Bigger Picture

NIKKI JONES

*The Oracle of Oil* by Mason Inman

W.W. Norton & Co. Ltd, 2016

ISBN 9780393239683

The name Marian King Hubbert is synonymous with the term ‘peak oil’, derided by many in the industry now that the ‘shale gale’ has taken hold. So this is a timely biography, giving a critical review of what Hubbert actually said, and an extraordinary insight into a life governed by data, logic and a fearless determination to discover truth.

Hubbert’s life as a young student is exhausting to read: taking geology and physics with math as a minor, he worked several jobs to pay his way and he even became a published scientist while still an undergraduate. At 26 he was offered a post leading a new geophysics program at Columbia. This life-long drive for knowledge and understanding came from a family that revered education. Even his names, Marian and King, were both chosen to honor men who had personally helped his mother get to school.

The physical world fascinated him. ‘It had never dawned on me that the world runs on mines,’ he wrote in his early 20s. As he began to study the coal industry, and as he watched oil companies tapping into the one big pool of the first big gusher, all fearful that another company might drain it first, the idea of ‘limits to growth’ entered his thinking.

His method was always to ‘get his hands dirty with the data’ before reading the theory, whether considering mountain folds, hydrodynamic entrapment, how fracking actually works, or nuclear waste disposal.

Hubbert applied the same relentless logic to the society he saw around him, the 1930s depression, the growth of corporate power and mass consumerism, the racial segregation and the profound economic inequalities of US society. He became a leading thinker and writer in the Technocracy movement, which saw the inconsistency and short-sightedness of government

as a major block to progress and ‘fair consumption’. The group’s ultimate goal was the ditching of politicians and their replacement with science-grounded technocrats. Hubbert liked to joke that he was fraternizing with the ‘most dangerous radicals in the US’.

Indeed, he did come under investigation as a potential subversive during the war period, and again in the McCarthy era. Only the fact that his

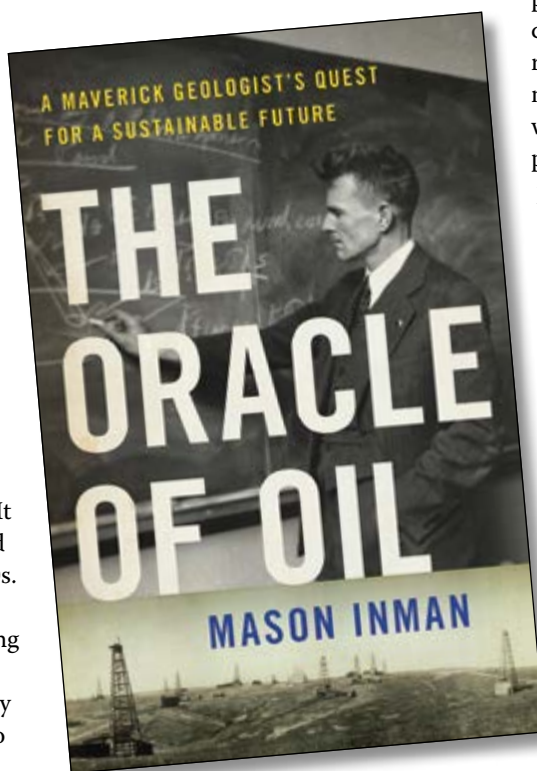

skills were irreplaceable for strategic resource planning, plus his relatively low public profile within the movement, kept his good name. He moved from the civil service to Shell.

### Predictions

Inman charts the difficult years when Hubbert began to draw his own conclusions on US and world discoveries and production. Through Inman’s eyes, we see some of the frustrations and sense of embattlement – as well as the fearless integrity and rigorous analysis – that led him to

become an extraordinary, inconvenient thorn in the flesh of the energy establishment. This was true for the nuclear industry with its waste disposal policies as much as for oil, and the two together when nuclear explosions were used to heat up and release tar sands in Project Cauldron. Hubbert’s loud verdict was that this was ‘irresponsible and almost insane’.

As Inman reminds us, Hubbert’s predictions were for US and world conventional oil and they have proved remarkably accurate – 1965–70 for US new discoveries and early 2000s for the world; around 12 years later for peak production. In the public mind, his predictions have become confused with the idea that the world was about to ‘run out’ of oil, which was categorically not his point.

Indeed, he was well aware of shale and tar sand deposits and agreed that ‘they should be able to supply all of our domestic requirements for a century or two’. America would not become ‘destitute of liquid fuels’. His estimate was that each additional 50 billion barrels would delay peak production by approximately five years. But he simply did not agree with the ‘shaky speculations by poorly informed writers’ that the US could ultimately produce another 300–600 billion barrels. From Hubbert’s point of view, these calculations appeared to be based on a wishful thinking that was not founded in data.

The oil industry still waits with baited breath to see how long the US shale industry will last and how transferable it is. What perhaps Hubbert did not foresee is the interaction with a complex finance system that enables an industry to function despite not covering its operating costs. Across the board, however, there is still enormous respect for the man who was relentless in his quest for fact and whose impact still resonates today. Inman’s biography is a must-read for truth-seekers everywhere. ■



Under the Patronage of  
His Royal Highness Prince Khalifa bin Salman Al Khalifa  
Prime Minister of the Kingdom of Bahrain

# **GEO 2018**

13<sup>th</sup> Middle East Geosciences  
Conference and Exhibition

CONFERENCE:

**5 – 8 March 2018**

EXHIBITION:

**6 – 8 March 2018**

BAHRAIN INTERNATIONAL EXHIBITION & CONVENTION CENTRE



**GEO2018.com**

CONFERENCE CHAIRED BY



SUPPORTED BY



EXHIBITION ORGANISERS



CONFERENCE ORGANISERS



# Senegal: Another Gas Find

**Kosmos Energy** has made another significant gas discovery on its Senegalese acreage with the **Yakaar 1** deepwater new field wildcat. Drilled in 2,550m of water in the **Cayar Offshore Profond** block, the well lies about 100 km west-north-west of the capital, Dakar, and is 20 km south-west of the recent large gas discoveries of the **Greater Tortue** area on the Mauritania/Senegal border, which are believed to hold a gross resource of more than 24 Tcf.

The well was drilled to 4,700m in 2,550m water depth and encountered a gross hydrocarbon column of 120m in three pools within the primary Lower Cenomanian objective and 45m net pay. Well results confirm the presence of thick, stacked, reservoir sands over a large area with very good porosity and permeability. Kosmos estimates Pmean gas resources from Yakaar 1 to be about 15 Tcfg, in-line with pre-drill expectations. Preliminary analysis of gas samples conducted on the rig suggest a condensate-to-gas ratio of approximately 15–30 bc/MMscfg. An appraisal program to delineate the discovery is currently being planned.

The Atwood Oceanics *Atwood Achiever* drillship which drilled Yakaar will now undertake a DST on the Tortue discovery, to enable the commencement of FEED activities in H2 2017. Kosmos then plans to drill several more wells over its Senegal and Mauritania acreage. Yakaar follows five successful gas wells drilled by Kosmos across Senegal and Mauritania since 2014; Tortue 1 (also known as Ahmeyim 1), Marsouin 1, Ahmeyim 2, Guembeul 1 and Teranga 1. The Greater Tortue gas field is

estimated by Kosmos to contain a Pmean gross resource of >25 Tcfg. An FLNG project is planned, and Kosmos believes that resources from Teranga 1 and Yakaar 1 together will provide enough gas to support a second LNG hub. BP farmed into the blocks in February 2017, acquiring equity and operatorship of future development projects from Kosmos, and in April 2017 it agreed to acquire an additional 30% equity from Timis Corp. Following the completion of this transaction, equity will be split BP (57.49%), Kosmos (32.51%) and Petrosen (10%). Kosmos remains the operator of the exploration phase. ■

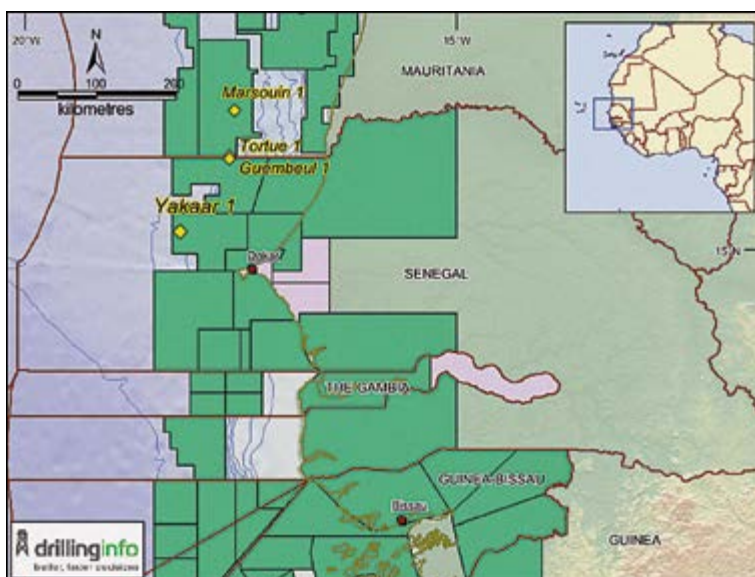

# Myanmar: Successful Appraisal

In late July 2017, **Woodside Energy (Myanmar)**, a wholly owned subsidiary of Woodside Petroleum Ltd, is understood to have suspended the gas-bearing **Pyi Thit 1** wildcat after the well had been drilled to 4,725m and logged, with the well flowing 20 MMcfd on a 24/64" choke and 35 MMcfd on a 32/64" choke.

Pyi Thit 1, which was spudded on June 8, 2017, is located in 2,000m of water in the 10,055 km<sup>2</sup> **Rakhine Offshore Basin Block A-6**, offshore south-west Myanmar and was an appraisal for the **Shwe Yee Htung 1** gas discovery, 6.6 km due north. It was targeting two gas-prone channel systems, analogous to Shwe Yee Htung 1, with up to seven other channel systems having been identified which may be explored further, providing significant follow-up potential.

Shwe Yee Htung 1 was plugged and abandoned in early January 2016 after being drilled to 5,306m and in May 2016, Woodside announced that the best estimate (P50) contingent resource estimate (2C) of the field was 895 Bcfg. If proven economic, the development of the field will be fast-tracked and tied back to the neighboring Yadana Gas Processing facilities located

in Block M-5, some 222 km south-east of the discovery.

Equity in Block A-6 is split between Woodside (40%), MPRL (20%) and Total E&P Myanmar (40%). ■

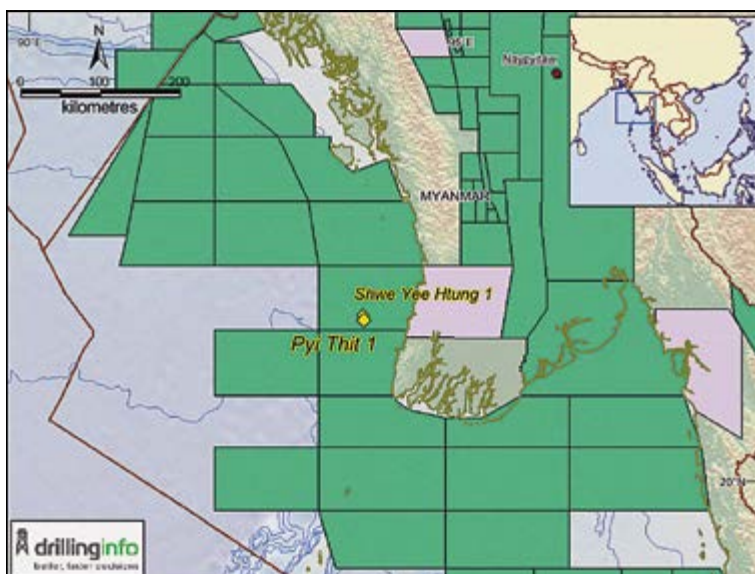



# Mexico: Significant Oil Discovery

Talos Energy made history in late July 2017 when it made the first ever private sector discovery of a new structure offshore Mexico. Its **Zama 1** wildcat, located on Block 7 (Contracto CNH-R01-L01-A7/2015) in 166m of water, approximately 60 km from the Mexican Gulf port of Dos Bocas, spudded on May 21, 2017. It found a contiguous gross oil-bearing interval of over 335m, with 170m–200m of net oil pay in Upper Miocene sandstones with no water contact. Drilling using the *Ensco 8503* semi-submersible continued to a TD of 4,108m into a secondary target, Zama Deep, but no additional hydrocarbons were encountered. The logging results confirmed the base of the reservoir section to be 3,380m, and initial tests of hydrocarbon samples recovered to the surface suggest light oil, with API gravities between 28° and 30°, and some associated gas.

The well has been suspended as a potential producer, and operator Talos, together with partners Sierra (40%) and Premier (25%), are analyzing the data to evaluate the best way to appraise and develop the discovery. Initial gross original oil-in-place estimates for the Zama-1 well range from 1.4 Bbo to 2 Bbo, exceeding pre-drill estimates, and some of the resource could extend into a neighboring block.

As reported in *GEO ExPro*, Vol. 14, No.3, earlier this year Eni made the first offshore oil discovery in Mexico since energy sector reforms enabled foreign companies to explore in the country, but this was part of an appraisal program. Zama is significant in that it found a completely new structure and field and can thus be considered a true exploration well. ■

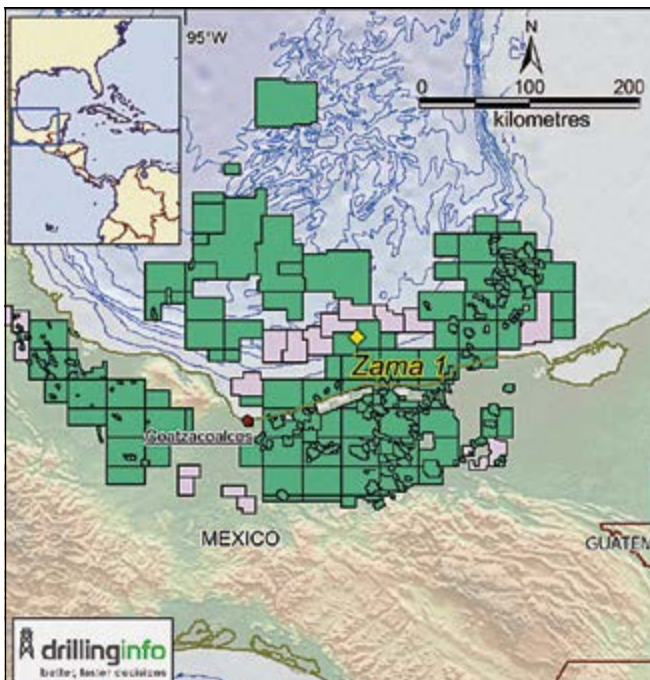

MICROg  
LACOSTE  
A DIVISION OF LRS

## GRAVITY SURVEYS BOREHOLE • ABSOLUTE TIME LAPSE • AIRBORNE

**APPLICATIONS:**  
RESERVOIR MONITORING  
CO<sub>2</sub> STORAGE MONITORING  
CARBONATE POROSITY  
OVERBURDEN PRESSURE  
LARGE VOLUME FLUID SATURATION  
REMOTE SENSING  
GEODETIC SURVEYS

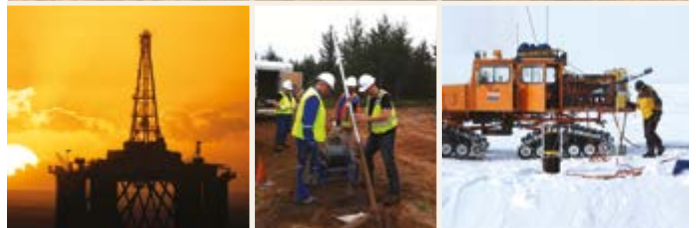

OFFSHORE

DEEP  
MINING

ABSOLUTE  
TIME LAPSE

Our highly experienced survey engineers and geophysicists, equipped with state of the art borehole, absolute, relative and airborne gravity equipment are available for demanding gravity surveys world-wide. We also provide feasibility studies using forward and inverse modeling of reservoir simulations. Contact us to discuss your program.

1401 Horizon Ave. Lafayette, CO 80026

+1 (303) 962-7984

survey@microglacoste.com • www.microglacoste.com

# US Tight Oil: Remaining Competitive?

THOMAS SMITH

***The US Lower 48 capital expenditure cuts have been massive, so where is the bulk of the investment for the Lower 48 going now?***

It's certainly earmarked for the Permian, and in that area it's mostly within the Wolfcamp zone. We estimate almost a third of all drilling and completion capital spent in 2017 will be put to work in the Midland and Delaware Basins. In oil terms, this is 50% of the total capital invested in onshore US oil assets. This year, Delaware investment will surpass Midland investment, and we forecast the relationship to stay that way over the next decade.

***What has changed in Woodmac's tight oil production forecasts the past six months?***

I don't think we're alone in the fact that we have had to continually raise our Permian supply outlook. Concerns around adding rigs and personnel turned out to be largely overdone. Permian rig count increased by almost 90 units in just the first six months of 2017. It turns out that many rig providers 'gold plated' their equipment during the downturn to give themselves the best opportunity to win back work during the rebound. The rigs have shown up – to say the least – and they've brought their A-game.

***What about cost inflation for 2017; how are operators handling any increases?***

Cost inflation is real, but producers and service companies have found smart ways to work together in a balanced fashion. Many new contracts have rates that are scaled to WTI prices. Spot market rates for tangible goods like proppant are rising, but to combat that, producers have really optimized their logistics and supply chain management.

***New and emerging technologies have not only made tight oil production possible, but a major player for the industry. After the initial price collapse and consolidation period, tight oil companies have started growing again. How is this possible with the current low oil prices?***

This is a complex issue and one that has – to be honest – baffled many investors. To answer it succinctly though, producers aggressively attacked both main areas that really impact US onshore economics: costs and productivity. Wells are drilled faster and cheaper. All non-essential material and time has been removed. Regarding productivity, completions are more effective and producers drilled their top prospects. "Better frac, best rock" is a simple way to say this.

Since the oil price collapse, upstream development spending has been cut worldwide at surprising rates. How is that changing the world of drilling unconventional plays in the US? We talk to **Robert Clarke**, a Lower 48 Research Director with Wood Mackenzie, who works closely with E&Ps, investors and service companies in the North Texas market.

***What variables and data points are Woodmac analysts currently paying the most attention to and why?***

Wells are clearly more productive today, but understanding the rate at which they've improved is important. What will cause productivity to rise even more, or conversely fall, as the best zip codes become fully developed? This obviously impacts future economics, Permian supply, and ultimately WTI prices. We're also looking at new project variables like the performance of child wells versus their parents, as well as the impact of frac hits for closely-spaced completions. Initially, frac hits appeared to be more of an issue for older, mature, conventional producers. We're now seeing infill well frac hits communicating with shale wells that were drilled just a few years ago.

***What will the near future hold for US tight oil? Still competitive in five years? Ten years?***

Definitely competitive in the near term; it gets complicated down the road though. Onshore costs are rising, while deepwater costs are falling. Some of the characteristics that made the Permian unique won't exist going forward. Today it's seeing a different scale of activity from a different set of companies. The collective set of Permian operators has done a fantastic job getting the play to where it is today, but they can't rest on their laurels. The best companies aren't, and they'll be the ultimate winners. ■

***Robert Clarke started out as a field geologist for a private engineering and consulting firm in Houston, Texas, before joining Wood Mackenzie. His specializations include geologic play description, decline curve analysis, production forecasting, analog play modeling and economic benchmarking.***







We can't see the future.  
But we can point the way.

Why choose between image quality, cost, and flexibility for your data acquisition strategy? Our Z Technology platform provides all three, with superior 4D data quality through wide-azimuth, long-offset, dense-shot geometries. Simple, scalable and HSE-friendly, it's ideal for complex infrastructure, providing cost-effective insight over the productive life of your field—which, with any luck, just got longer.

**Right image. Right economics. Right team.**



# Oil is No. 1

Despite a strong growth in the use of renewables, oil is by far the preferred energy carrier.

When somebody tells you that the oil age is soon to end, and that renewables will dominate in the near future, remind them that wind, solar, biofuel and geothermal energy combined account for only 3.2% of the world's energy production today. And with a similar increase in 2017 as in 2016 (14%), this will rise to only 3.6% in 2017.

In their latest review of world energy, BP states that global primary energy consumption increased by roughly 1% in 2016. This is comparable to 2014 and 2015, but somewhat lower than the 10-year average of 1.8% a year. Approximately 30% of the increase was covered by renewables, while oil accounted for around 50% of the rise.

Renewable energy was again the fastest growing energy source, according to the *BP Statistical Review of World Energy 2017*. Remarkably, China continued to dominate renewables growth, contributing over 40% to global growth.

However, oil provided the largest contribution to growth measured in oil equivalents, the reason supposedly being low oil prices boosting demand. Moreover, following the decline in the use of coal over the past few years, with 33% of the market oil remains the world's preferred energy carrier. Coal has only 28% of the market, while gas has 24%. In other words, fossil fuels combined have the lion's share at 85%.

Like it or not, there is a long way to go before renewables will dominate and fossil fuels become outdated.

## How to Replace Oil?

With a continued resistance to the use of coal in many countries (coal production fell 8.8% in the US in 2016), there is also a question of how these huge volumes are going to be replaced. In addition, we continue to increase our energy consumption by approximately 1% every year. In a world flush with oil, at the moment renewables are not likely to grow fast enough to replace coal.

This is substantiated by the fact that in 2016 global coal consumption fell by 53 million tonnes of oil equivalents (389 MMboe), while the 14% growth in renewables meant an increase of similar magnitude. In other words, if coal consumption is going to fall in a similar way over the next few years, an enormous increase in wind and solar capacity, far beyond what is theoretically achievable, will be required to replace it. We may therefore end up with oil and gas replacing coal. Renewables will only partly cover the increase in energy demand.

Oil and gas are here to stay. ■

Halfdan Carstens

*Our current use of hydroelectric power is equivalent to burning 18 MMbopd and accounts for almost 7% of our energy use. That is more than twice the use of renewable energy including wind, solar, biofuel and geothermal.*



## Conversion Factors

### Crude oil

- 1 m<sup>3</sup> = 6.29 barrels
- 1 barrel = 0.159 m<sup>3</sup>
- 1 tonne = 7.49 barrels

### Natural gas

- 1 m<sup>3</sup> = 35.3 ft<sup>3</sup>
- 1 ft<sup>3</sup> = 0.028 m<sup>3</sup>

### Energy

- 1000 m<sup>3</sup> gas = 1 m<sup>3</sup> o.e
- 1 tonne NGL = 1.9 m<sup>3</sup> o.e.

### Numbers

- Million = 1 x 10<sup>6</sup>
- Billion = 1 x 10<sup>9</sup>
- Trillion = 1 x 10<sup>12</sup>

### Supergiant field

Recoverable reserves > 5 billion barrels (800 million Sm<sup>3</sup>) of oil equivalents

### Giant field

Recoverable reserves > 500 million barrels (80 million Sm<sup>3</sup>) of oil equivalents

### Major field

Recoverable reserves > 100 million barrels (16 million Sm<sup>3</sup>) of oil equivalents

## Historic oil price

Crude Oil Prices Since 1861

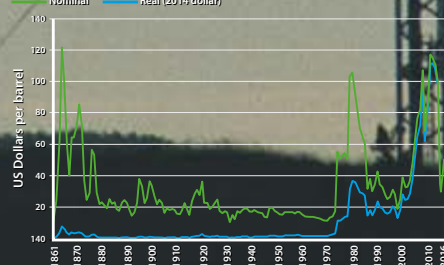



# Onshore Data Library

TGS offers multi-client onshore data across North America and applies the same high standards of quality and customer service with onshore seismic as with its suite of geoscience data products around the world. With recent seismic development in the Permian and continued growth in the Anadarko Basin, TGS has positioned itself as the leading onshore data provider in these prolific regions.

TGS' extensive data library consists of a comprehensive suite of products including seismic data, interpretation services, reservoir characterization and well data packages, offering clients a complete overview of subsurface potentials. With such diversity of available products, TGS has the most complete, top to bottom, basin-wide views the industry has to offer.

Let's Explore.

## Anadarko Basin

- +1,500 sq. miles of 3D seismic data
- +160,000 smartRASTERS
- +97,000 Digital LAS
- +105,000 Validated Well Headers
- +10,000 Directional Surveys
- +1 Basin Temperature Model
- + Formation Tops

## Permian Basin

- +300 sq. miles of 3D seismic data in acquisition
- +430,000 smartRASTERS
- +290,000 Digital LAS
- +375,000 Validated Well Headers
- +24,000 Directional Surveys
- +3 Basin Temperature Models
- + Formation Tops



# Barents Sea: Norsel High

New Broadband 3D Seismic for Key 24<sup>th</sup> Round Evaluation

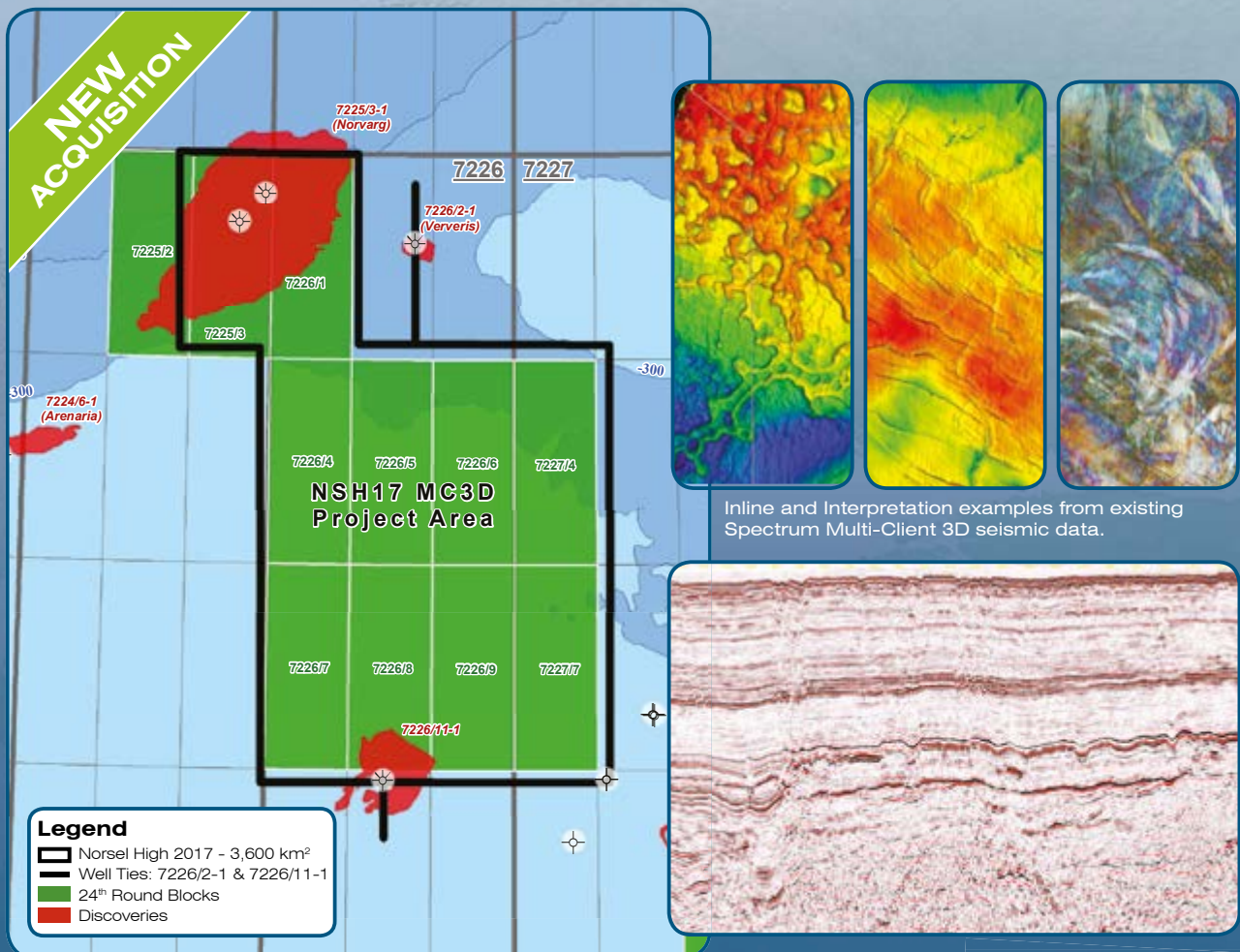

Spectrum offers a new Multi-Client broadband 3D seismic dataset over the Norsel High in the Barents Sea, specifically designed to facilitate 3D evaluation of key acreage available in the 24<sup>th</sup> Round. The NSH17 program comprises 1,600 km<sup>2</sup> of new acquisition and 2,000 km<sup>2</sup> of 3D broadband reprocessing resulting in a single contiguous, conformable seismic dataset of 3,600 km<sup>2</sup>, covering 10 prospective blocks.

The highest quality possible Fast-track 3D volume is available now, allowing for early evaluation before the 30th November application deadline. Further interim Pre-Stack Time Migration data will be made available in time for application revision.

